

IEEE Guide for Application of Shunt Power Capacitors

Sponsor

**Transmission and Distribution Committee
of the
IEEE Power Engineering Society**

Approved September 17, 1992

IEEE Standards Board

Abstract: Guidelines for the application, protection, and ratings of equipment for the safe and reliable utilization of shunt power capacitors are provided. This guide applies to the use of 50 and 60 Hz shunt power capacitors rated 2400 Vac and above, and assemblies of capacitors. Applications that range from simple unit utilization to complex bank situations are covered.

Keywords: capacitor, power factor correction, shunt power capacitor, voltage control

The Institute of Electrical and Electronics Engineers, Inc.
345 East 47th Street, New York, NY 10017-2394, USA

Copyright © 1993 by the Institute of Electrical and Electronics Engineers, Inc.
All rights reserved. Published 1993. Printed in the United States of America

ISBN 1-55937-257-5

No part of this publication may be reproduced in any form, in an electronic retrieval system or otherwise, without the prior written permission of the publisher.

IEEE Standards documents are developed within the Technical Committees of the IEEE Societies and the Standards Coordinating Committees of the IEEE Standards Board. Members of the committees serve voluntarily and without compensation. They are not necessarily members of the Institute. The standards developed within IEEE represent a consensus of the broad expertise on the subject within the Institute as well as those activities outside of IEEE that have expressed an interest in participating in the development of the standard.

Use of an IEEE Standard is wholly voluntary. The existence of an IEEE Standard does not imply that there are no other ways to produce, test, measure, purchase, market, or provide other goods and services related to the scope of the IEEE Standard. Furthermore, the viewpoint expressed at the time a standard is approved and issued is subject to change brought about through developments in the state of the art and comments received from users of the standard. Every IEEE Standard is subjected to review at least every five years for revision or reaffirmation. When a document is more than five years old and has not been reaffirmed, it is reasonable to conclude that its contents, although still of some value, do not wholly reflect the present state of the art. Users are cautioned to check to determine that they have the latest edition of any IEEE Standard.

Comments for revision of IEEE Standards are welcome from any interested party, regardless of membership affiliation with IEEE. Suggestions for changes in documents should be in the form of a proposed change of text, together with appropriate supporting comments.

Interpretations: Occasionally questions may arise regarding the meaning of portions of standards as they relate to specific applications. When the need for interpretations is brought to the attention of IEEE, the Institute will initiate action to prepare appropriate responses. Since IEEE Standards represent a consensus of all concerned interests, it is important to ensure that any interpretation has also received the concurrence of a balance of interests. For this reason IEEE and the members of its technical committees are not able to provide an instant response to interpretation requests except in those cases where the matter has previously received formal consideration.

Comments on standards and requests for interpretations should be addressed to:

Secretary, IEEE Standards Board
445 Hoes Lane
P.O. Box 1331
Piscataway, NJ 08855-1331
USA

<p>IEEE Standards documents are adopted by the Institute of Electrical and Electronics Engineers without regard to whether their adoption may involve patents on articles, materials, or processes. Such adoption does not assume any liability to any patent owner, nor does it assume any obligation whatever to parties adopting the standards documents.</p>
--

Introduction

(This introduction is not a part of IEEE Std 1036-1992, IEEE Guide for Application of Shunt Power Capacitors.)

This application guide was prepared in response to a need created by the increasing use of shunt power capacitor banks at virtually all distribution and transmission voltage levels. Its objective is to provide a basis for reliability and quality in design, application, and protection of shunt capacitor banks. This standard was developed by an IEEE Working Group sponsored by the Capacitor Subcommittee of the Transmission and Distribution Committee of the IEEE Power Engineering Society. At the time it approved this guide, the Capacitor Subcommittee had the following membership:

W. E. Reid, *Chair*
B. C. Furumasa, *Secretary*

I. Ares	J. E. Harder	A. S. Mehraban
F. D. Barrow, Jr.	W. M. Hurst	S. A. Miske
B. Bhargava	S. B. Ladd	G. R. Newcomb
J. A. Bonner	J. A. LaPoint	D. R. Ruthman
S. H. Cheng	J. Lapp	J. Samuelsson
H. E. Church	J. W. Lineberger	R. Thallam
C. R. Cusick	A. Macquire	K. K. Williams
G. R. Hanks	J. Maneatis	T. C. Wong

The members of the Working Group were as follows:

W. E. Reid, *Chair*

F. D. Barrow, Jr.	G. R. Hanks	S. B. Ladd
S. H. Cheng	J. E. Harder	J. A. LaPoint
H. E. Church	W. M. Hurst	J. W. Lineberger
B. C. Furumasa		G. R. Newcomb

The following persons were on the balloting committee that approved this document for submission to the IEEE Standards Board:

James J. Burke	J. G. Kappenman	Stig L. Nilsson
K. R. Chakravarthi	George Karady	R. G. Oswald
Vernon L. Chartier	J. Lapp	Fred Picciano
C. C. Diamond	Keith E. Lindsey	F. S. Prabhakara
L. H. Fink	J. H. Mallory	W. Edward Reid
Donald A. Gillies	Thomas J. McDermott	Farouk A. M. Rizk
I. S. Grant	Franklin D. Myers	Richard G. Rocamora
W. S. C. Henry	D. L. Nickel	B. R. Shperling

When the IEEE Standards Board approved this standard on Sept. 17, 1992, it had the following membership:

Marco W. Migliaro, *Chair* **Donald C. Loughry, *Vice Chair***
Andrew G. Salem, *Secretary*

Dennis Bodson	Donald N. Heirman	T. Don Michael*
Paul L. Borrill	Ben C. Johnson	John L. Rankine
Clyde Camp	Walter J. Karplus	Wallace S. Read
Donald C. Fleckenstein	Ivor N. Knight	Ronald H. Reimer
Jay Forster*	Joseph Koepfinger*	Gary S. Robinson
David F. Franklin	Irving Kolodny	Martin V. Schneider
Ramiro Garcia	D. N. "Jim" Logothesis	Terrance R. Whittemore
Thomas L. Hannan	Lawrence V. McCall	Donald W. Zipse

*Member Emeritus

Also included are the following nonvoting IEEE Standards Board liaisons:

Satish K. Aggarwal	Richard B. Engelman	David E. Soffrin
James Beall		Stanley Warshaw
	Paula M. Kelty	
	<i>IEEE Standards Project Editor</i>	

Contents

CLAUSE	PAGE
1. Overview.....	1
1.1 Scope.....	1
1.2 References.....	1
1.3 Definitions	2
2. Purpose of shunt power capacitors	2
2.1 Var support	3
2.2 Voltage control	4
2.3 Increased system capacity.....	4
2.4 Reduced system power losses.....	6
2.5 Reduced billing charges.....	7
3. Capacitor ratings and service conditions	7
3.1 Ratings	7
3.2 Service conditions.....	9
4. Capacitor applications on distribution lines.....	10
4.1 Sizing and locating capacitors	11
4.2 Switching of capacitors.....	12
4.3 Switchgear ratings.....	13
4.4 Protection	14
4.5 Harmonic considerations	17
5. Substation shunt power capacitor bank applications	17
5.1 Size and number of banks	18
5.2 Bank configurations.....	20
5.3 Capacitor bank switching.....	21
5.4 Outrush current	29
5.5 Harmonics.....	32
5.6 Protection	34
6. Special capacitor applications.....	35
6.1 Harmonic filters	35
6.2 Motor applications	38
6.3 Surge capacitors.....	39
7. Inspection and maintenance.....	41
7.1 General.....	41
7.2 Safety and personnel protection.....	41
7.3 Initial inspection, measurements, and energization	42
7.4 Periodic inspection, measurements, and maintenance.....	42
7.5 Field testing.....	43

8. Bibliography	44
-----------------------	----

IEEE Guide for Application of Shunt Power Capacitors

1. Overview

1.1 Scope

This guide applies to the use of 50 and 60 Hz shunt power capacitors rated 2400 Vac and above, and assemblies of capacitors. Included are guidelines for the application, protection, and ratings of equipment for the safe and reliable utilization of shunt power capacitors. The guide is general and intended to be basic and supplemental to specific recommendations of the manufacturer. The guide covers applications that range from simple unit utilization to complex bank situations.

1.2 References

This application guide shall be used in conjunction with the following publications. When the following standards are superseded by an approved revision, the revision shall apply:

ANSI C2-1990, National Electrical Safety Code.¹

ANSI C37.06-1987, American National Standard for AC High-Voltage Circuit Breakers Rated on a Symmetrical Current Basis—Preferred Ratings and Related Required Capabilities.²

ANSI/NFPA 70-1993, National Electrical Code.³

IEEE Std C37.04-1979 (Reaff 1988), IEEE Standard Rating Structure for AC High-Voltage Circuit Breakers Rated on a Symmetrical Current Basis (ANSI).⁴

IEEE Std C37.012-1979 (Reaff 1988), IEEE Application Guide for Capacitance Current Switching for AC High-Voltage Circuit Breakers Rated on a Symmetrical Current Basis (ANSI).

IEEE Std C37.99-1990, IEEE Guide for Protection of Shunt Capacitor Banks (ANSI).

IEEE Std C62.2-1987, IEEE Guide for the Application of Gapped Silicon-Carbide Surge Arresters for Alternating-Current Systems (ANSI).

IEEE Std 18-1992, IEEE Standard for Shunt Power Capacitors.

IEEE Std 100-1992, The New IEEE Standard Dictionary of Electrical and Electronics Terms.

IEEE Std 141-1986, IEEE Recommended Practice for Electric Power Distribution for Industrial Plants (IEEE Red Book) (ANSI).

¹The National Electrical Safety Code is available from the Institute of Electrical and Electronics Engineers, Service Center, 445 Hoes Lane, P.O. Box 1331, Piscataway, NJ 08855-1331, USA; and from the Sales Department, American National Standards Institute, 11 West 42nd Street, 13th Floor, New York, NY 10036, USA.

²ANSI publications are available from the Sales Department, American National Standards Institute, 11 West 42nd Street, 13th Floor, New York, NY 10036, USA.

³NFPA publications are available from Publications Sales, National Fire Protection Association, 1 Batterymarch Park, P.O. Box 9101, Quincy, MA 02269-9101, USA.

⁴IEEE publications are available from the Institute of Electrical and Electronics Engineers, Service Center, 445 Hoes Lane, P.O. Box 1331, Piscataway, NJ 08855-1331, USA.

IEEE Std 519-1992, IEEE Guide for Harmonic Control and Reactive Compensation of Static Power Converters.

1.3 Definitions

1.3.1 back-to-back switching. The switching of a capacitor bank that is connected in parallel with one or more other capacitor banks.

1.3.2 capacitor control. The device required to automatically switch shunt power capacitor banks.

1.3.3 capacitor inrush current. The transient charging current that flows in a capacitor when a capacitor bank is initially connected to a voltage source.

1.3.4 capacitor line fuse (capacitor group fuse). A fuse applied to disconnect a faulted phase of its capacitor bank from a power system.

1.3.5 capacitor outrush current. The high-frequency, high-magnitude current discharge of one or more capacitors into a short circuit—such as into a failed capacitor unit connected in parallel with the discharging units, or into a breaker closing into a fault.

1.3.6 filter capacitors. Capacitors utilized with inductors and/or resistors for controlling harmonic problems in the power system, such as reducing voltage distortion due to large rectifier loads or arc furnaces.

1.3.7 fixed bank. A capacitor bank that does not have a capacitor control and must be manually switched.

1.3.8 individual capacitor fuse. A fuse applied to disconnect an individual faulted capacitor from its bank.

1.3.9 isolated capacitor bank. A capacitor bank that is not in parallel with other capacitor banks.

1.3.10 switched bank. A capacitor bank designed for controlled operation.

2. Purpose of shunt power capacitors

Most power system loads and delivery apparatus (e.g., lines and transformers) are inductive in nature and therefore operate at a lagging power factor. When operating at a lagging power factor, a power system requires additional var flow, which results in reduced system capacity, increased system losses, and reduced system voltage.

Figure 1 illustrates how the application of shunt power capacitors increases system capacity and reduces system losses by reducing var flow. The system load is reduced from kVA_1 to kVA_2 by the addition of the capacitive kilovar, shown in figure 1 as $Ckvar$. Table 1 gives a summary of benefits derived from shunt power capacitors as they apply to transmission and distribution systems. Var support and voltage control are the primary benefits for a transmission system while the distribution system benefits may be more varied depending upon whether the system belongs to a generating utility, a nongenerating utility, or an industrial power user. The following subclauses describe each of these benefits in more detail.

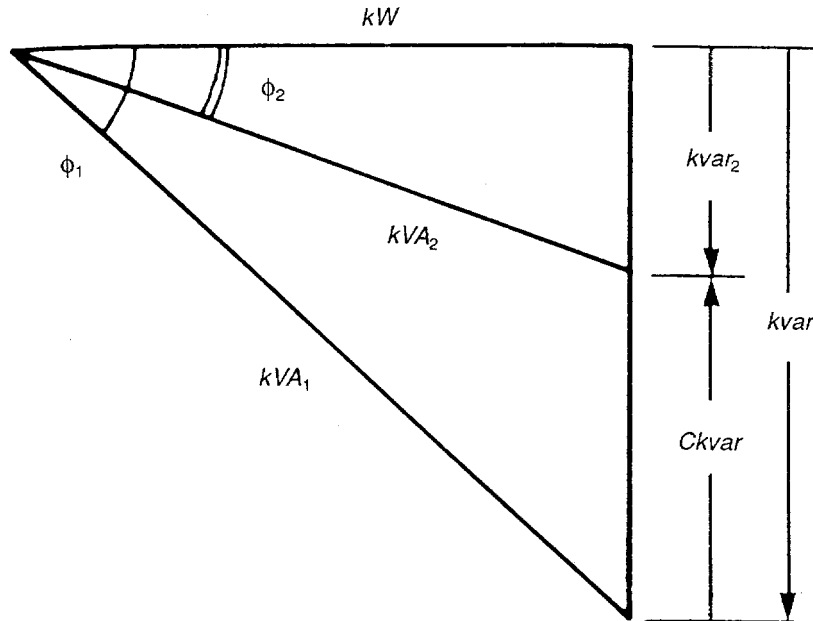

Figure 1—Effect of adding shunt capacitors

Table 1—Summary of benefits of applying shunt power capacitors

Benefits	Transmission system	Distribution system
Var support	*	†
Voltage control	*	*
Increase system capacity	†	*
Reduce system power loss	†	*
Reduce billing charges	—	*

*This is generally a primary benefit.
†This is generally a secondary benefit.

2.1 Var support

Var support encompasses many of the different benefits of shunt power capacitors, such as improved voltage control and power factor, reduced system losses and reactive power requirements at generators, and increased steady-state stability limits. Capacitive vars are sized and located at transmission and distribution substations to supply vars close to the loads or to provide midway support across heavily loaded transmission circuits.

2.2 Voltage control

Applying capacitors to a system will result in a voltage rise in the system from the point of installation back to the generation. In a system with lagging power factor, this occurs because capacitors may reduce the amount of reactive current being carried in the system, thus decreasing the amount of resistive and reactive voltage drop in the system.

There are a number of formulas that can be used to estimate the voltage rise that capacitors will produce. A commonly used one is as follows:

$$\Delta V = \frac{(kvar)(X_L)}{10(kV)^2}$$

where

- ΔV is the percent voltage rise at the point of the capacitor installation
- kV is the system line-to-line voltage without capacitor in service
- $kvar$ is the three-phase kilovar rating of the capacitor bank
- X_L is the inductive reactance of the system at the point of the capacitor installation, in ohms

Capacitor banks are typically installed on the transmission system at major buses to provide voltage support for a large area. They are also installed at distribution buses and directly on customer delivery buses to provide voltage support to smaller areas and to individual customers. Capacitor banks installed on distribution lines support voltage along the entire length of line.

Capacitor banks that are installed for voltage support are generally switched on during the peak loading periods or low-voltage conditions and switched off during light loading periods or high-voltage conditions.

2.3 Increased system capacity

Increased system capacity is often the most important benefit justifying the addition of shunt power capacitors on a distribution system. This is particularly significant when loads supplied by the system are increasing rapidly. The addition of shunt power capacitors reduces the kilovoltampere loading on the system, thereby releasing capacity that can then be used to supply future load increases. The optimum economical power factor for a system, with regard to released capacity only, can be estimated by use of the following formula:

$$PF = \sqrt{1 - \left(\frac{C_i}{S_i}\right)^2}$$

where

- C is the cost per kilovar of capacitor bank
- S is the cost per kilovoltamperes of system equipment
- PF is optimum power factor

The formula compares the cost of capacitor banks to the cost of transformers, regulators, etc., as alternative means of providing increased system capacity. The graph of the formula, the optimum power factor as a function of the cost ratio of the capacitor bank versus other system equipment, is illustrated in figure 2.

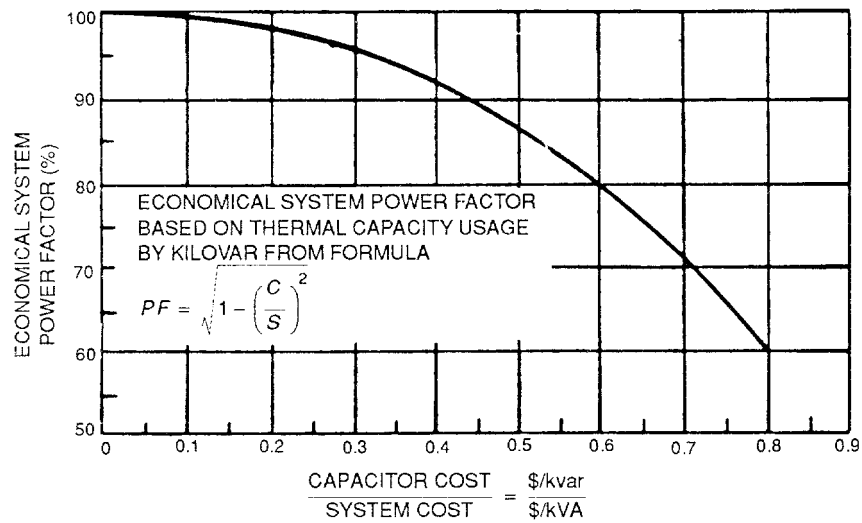

Figure 2—Economical system power factor

The power factor required to release a desired amount of system kilovoltamperes can be determined by the following formula:

$$PF_{\text{new}} = \frac{PF_{\text{old}}}{1 - kVA_{\text{release}}}$$

where

PF_{new} is the corrected power factor

PF_{old} is the existing power factor

kVA_{release} is the amount of kilovoltamperes to be released (in per unit of existing kilovoltamperes)

To calculate the capacitive kilovar necessary to correct to a new, higher power factor, one must subtract the inductive kvar of the new (corrected) power factor from the old (existing) power factor. The difference is the amount of capacitive kilovar to be added to the system. The following formula is a convenient way of doing this:

$$kvar = kW[\tan(\cos^{-1}PF_{\text{old}}) - \tan(\cos^{-1}PF_{\text{new}})]$$

where

kW is the system kilowatt load

$kvar$ is the amount of capacitive kilovar to be added

Table 2 is a chart that may be used in place of this formula. Simply find the row corresponding to the existing system power factor and the column corresponding to the corrected new power factor. The number located where these intersect should be multiplied by the system kilowatt load to arrive at the total capacitive kilovar necessary to correct to the new power factor.

Table 2—Power factor correction kilowatt multipliers

	Corrected power factor																				
	0.80	0.81	0.82	0.83	0.84	0.85	0.86	0.87	0.88	0.89	0.90	0.91	0.92	0.93	0.94	0.95	0.96	0.97	0.98	0.99	1.0
0.50	0.982	1.008	1.034	1.060	1.086	1.112	1.139	1.165	1.192	1.220	1.248	1.276	1.306	1.337	1.369	1.403	1.440	1.481	1.529	1.589	1.732
0.51	0.937	0.962	0.989	1.015	1.041	1.067	1.094	1.120	1.147	1.175	1.203	1.231	1.261	1.292	1.324	1.358	1.395	1.436	1.484	1.544	1.687
0.52	0.893	0.919	0.945	0.971	0.997	1.023	1.050	1.076	1.103	1.131	1.159	1.187	1.217	1.248	1.280	1.314	1.351	1.392	1.440	1.500	1.643
0.53	0.850	0.876	0.902	0.928	0.954	0.980	1.007	1.033	1.060	1.088	1.116	1.144	1.174	1.205	1.237	1.271	1.308	1.349	1.397	1.457	1.600
0.54	0.809	0.835	0.861	0.887	0.913	0.939	0.966	0.992	1.019	1.047	1.075	1.103	1.133	1.164	1.196	1.230	1.267	1.308	1.356	1.416	1.559
0.55	0.769	0.795	0.821	0.847	0.873	0.899	0.926	0.952	0.979	1.007	1.035	1.063	1.093	1.124	1.156	1.190	1.227	1.268	1.316	1.376	1.519
0.56	0.730	0.756	0.782	0.808	0.834	0.860	0.887	0.913	0.940	0.968	0.996	1.024	1.054	1.085	1.117	1.151	1.188	1.229	1.277	1.337	1.480
0.57	0.692	0.718	0.744	0.770	0.796	0.822	0.849	0.875	0.902	0.930	0.958	0.986	1.016	1.047	1.079	1.113	1.150	1.191	1.239	1.299	1.442
0.58	0.655	0.681	0.707	0.733	0.759	0.785	0.812	0.838	0.865	0.893	0.921	0.949	0.979	1.010	1.042	1.076	1.113	1.154	1.202	1.262	1.405
0.59	0.619	0.645	0.671	0.697	0.723	0.749	0.776	0.802	0.829	0.857	0.885	0.913	0.943	0.974	1.006	1.040	1.077	1.118	1.166	1.226	1.369
0.60	0.583	0.609	0.635	0.661	0.687	0.713	0.740	0.766	0.793	0.821	0.849	0.877	0.907	0.938	0.970	1.004	1.041	1.082	1.130	1.190	1.333
0.61	0.549	0.575	0.601	0.627	0.653	0.679	0.706	0.732	0.759	0.787	0.815	0.843	0.873	0.904	0.936	0.970	1.007	1.048	1.096	1.156	1.299
0.62	0.516	0.542	0.568	0.594	0.620	0.646	0.673	0.699	0.726	0.754	0.782	0.810	0.840	0.871	0.903	0.937	0.974	1.015	1.063	1.123	1.266
0.63	0.483	0.509	0.535	0.561	0.587	0.613	0.640	0.666	0.693	0.721	0.749	0.777	0.807	0.838	0.870	0.904	0.941	0.982	1.030	1.090	1.233
0.64	0.451	0.477	0.503	0.529	0.555	0.581	0.608	0.634	0.661	0.689	0.717	0.745	0.775	0.806	0.838	0.872	0.909	0.950	0.998	1.068	1.201
0.65	0.419	0.445	0.471	0.497	0.523	0.549	0.576	0.602	0.629	0.657	0.685	0.713	0.743	0.774	0.806	0.840	0.877	0.918	0.966	1.026	1.169
0.66	0.388	0.414	0.440	0.466	0.492	0.518	0.545	0.571	0.598	0.626	0.654	0.682	0.712	0.743	0.775	0.809	0.846	0.887	0.935	0.995	1.138
0.67	0.358	0.384	0.410	0.436	0.462	0.488	0.515	0.541	0.568	0.596	0.624	0.652	0.682	0.713	0.745	0.779	0.816	0.857	0.905	0.965	1.108
0.68	0.328	0.354	0.380	0.406	0.432	0.458	0.485	0.511	0.538	0.566	0.594	0.622	0.652	0.683	0.715	0.749	0.786	0.827	0.875	0.935	1.078
0.69	0.299	0.325	0.351	0.377	0.403	0.429	0.456	0.482	0.509	0.537	0.565	0.593	0.623	0.654	0.686	0.720	0.757	0.798	0.846	0.906	1.049
0.70	0.270	0.296	0.322	0.348	0.374	0.400	0.427	0.453	0.480	0.508	0.536	0.564	0.594	0.625	0.657	0.691	0.728	0.769	0.817	0.877	1.020
0.71	0.242	0.268	0.294	0.320	0.346	0.372	0.399	0.425	0.452	0.480	0.508	0.536	0.566	0.597	0.629	0.663	0.700	0.741	0.789	0.849	0.992
0.72	0.214	0.240	0.266	0.292	0.318	0.344	0.371	0.397	0.424	0.452	0.480	0.508	0.538	0.569	0.601	0.635	0.672	0.713	0.761	0.821	0.964
0.73	0.186	0.212	0.238	0.264	0.290	0.316	0.343	0.369	0.396	0.424	0.452	0.480	0.510	0.541	0.573	0.607	0.644	0.685	0.733	0.793	0.936
0.74	0.159	0.185	0.211	0.237	0.263	0.289	0.316	0.342	0.369	0.397	0.425	0.453	0.483	0.514	0.546	0.580	0.617	0.658	0.706	0.766	0.909
0.75	0.132	0.158	0.184	0.210	0.236	0.262	0.289	0.315	0.342	0.370	0.398	0.426	0.456	0.487	0.519	0.553	0.590	0.631	0.679	0.739	0.882
0.76	0.105	0.131	0.157	0.183	0.209	0.235	0.262	0.288	0.315	0.343	0.371	0.399	0.429	0.460	0.492	0.526	0.563	0.604	0.652	0.712	0.855
0.77	0.079	0.105	0.131	0.157	0.183	0.209	0.236	0.262	0.289	0.317	0.345	0.373	0.403	0.434	0.466	0.500	0.537	0.578	0.626	0.685	0.829
0.78	0.052	0.078	0.104	0.130	0.156	0.182	0.209	0.235	0.262	0.290	0.318	0.346	0.376	0.407	0.439	0.473	0.510	0.551	0.599	0.659	0.802
0.79	0.026	0.052	0.078	0.104	0.130	0.156	0.183	0.209	0.236	0.264	0.292	0.320	0.350	0.381	0.413	0.447	0.484	0.525	0.573	0.633	0.776
0.80	0.000	0.026	0.052	0.078	0.104	0.130	0.157	0.183	0.210	0.238	0.266	0.294	0.324	0.355	0.387	0.421	0.458	0.499	0.547	0.609	0.750
0.81		0.000	0.026	0.052	0.078	0.104	0.131	0.157	0.184	0.212	0.240	0.268	0.298	0.329	0.361	0.395	0.432	0.473	0.521	0.581	0.724
0.82			0.000	0.026	0.052	0.078	0.105	0.131	0.158	0.186	0.214	0.242	0.272	0.303	0.335	0.369	0.406	0.447	0.495	0.555	0.698
0.83				0.000	0.026	0.052	0.079	0.105	0.132	0.160	0.188	0.216	0.246	0.277	0.309	0.343	0.380	0.421	0.469	0.529	0.672
0.84					0.000	0.026	0.053	0.079	0.106	0.134	0.162	0.190	0.220	0.251	0.283	0.317	0.354	0.395	0.443	0.503	0.646
0.85						0.000	0.027	0.053	0.080	0.108	0.136	0.164	0.194	0.225	0.257	0.291	0.328	0.369	0.417	0.477	0.620
0.86							0.000	0.026	0.053	0.081	0.109	0.137	0.167	0.198	0.230	0.264	0.301	0.342	0.390	0.450	0.593
0.87								0.000	0.027	0.055	0.083	0.111	0.141	0.172	0.204	0.238	0.275	0.316	0.364	0.424	0.567
0.88									0.000	0.028	0.056	0.084	0.114	0.145	0.177	0.211	0.248	0.289	0.337	0.397	0.540
0.89										0.000	0.028	0.056	0.086	0.117	0.149	0.183	0.220	0.261	0.309	0.369	0.512
0.90											0.000	0.028	0.058	0.089	0.121	0.155	0.192	0.233	0.281	0.341	0.484
0.91												0.000	0.30	0.061	0.093	0.127	0.164	0.205	0.253	0.313	0.456
0.92													0.000	0.031	0.063	0.097	0.134	0.175	0.223	0.283	0.426
0.93														0.000	0.032	0.066	0.103	0.144	0.192	0.252	0.395
0.94															0.000	0.034	0.071	0.112	0.160	0.220	0.363
0.95																0.000	0.037	0.079	0.126	0.186	0.329
0.96																	0.000	0.041	0.089	0.149	0.292
0.97																		0.000	0.048	0.108	0.251
0.98																			0.000	0.060	0.203
0.99																				0.000	0.143
																					0.000

2.4 Reduced system power losses

On some distribution and transmission systems, a significant reduction in losses may be achieved by the installation of shunt power capacitors.

The installation of shunt power capacitors can reduce current flow through the system from the point of the capacitor installation back to the generation. Since power losses are directly proportional to the square of the

current, a reduction of current flow results in a much greater reduction of power losses. Capacitors are often installed as close to the load as possible for this reason.

The ratio of the system losses associated with the local load, with and without capacitors installed, can be estimated with the following formula. The formula assumes constant kilowatt and constant voltage at the load.

$$\begin{aligned} \text{loss ratio} &= \frac{\text{loss with capacitors}}{\text{loss without capacitors}} \\ &= \left(\frac{PF_{\text{old}}}{PF_{\text{new}}} \right)^2 \end{aligned}$$

where

PF_{old} is the existing power factor
 PF_{new} is the corrected power factor

This reduction in losses will reduce the generation fuel requirement to supply these losses as well as the system equipment costs to supply the losses at peak load.

2.5 Reduced billing charges

A number of utilities use some form of kilovoltampere billing for their larger customers (e.g., utilities and large industrial customers). Since the application of shunt power capacitors can result in a reduced kilovoltampere loading, this can result in reduced billing charges.

The kilovoltampere billing charge may be calculated in many different ways, including the following:

- a) A fixed dollar amount for each kilowatt plus a fixed dollar amount for each kilovar.
- b) A certain dollar amount for each kilowatt at or above a certain power factor, with additional charges made for each kvar in excess of that required by a minimum power factor.
- c) A charge per kilowatt demand multiplied by a factor that increases with decreasing power factor.
- d) A fixed charge per peak kilovoltampere.

3. Capacitor ratings and service conditions

Capacitor ratings and service conditions are specified in IEEE Std 18-1992. Key aspects of the ratings and service conditions are given here for easy reference.

3.1 Ratings

3.1.1 Standard Ratings

- a) Voltage, rms (terminal-to-terminal)
- b) Terminal-to-case (or ground) insulation class
- c) Reactive power
- d) Number of phases
- e) Frequency

3.1.2 Tolerances in ratings

3.1.2.1

Capacitors give not less than the rated reactive power at rated sinusoidal voltage and frequency, and not more than 115% of this value, measured at 25 °C uniform case and internal temperature.

3.1.2.2

Capacitors are suitable for continuous operation at 135% of rated reactive power. This maximum reactive power includes the following factors, the combined effects not exceeding 135%.

- a) Reactive power due to voltage in excess of nameplate rating at fundamental frequency but within the permissible voltage limitations described in 3.1.2.3.
- b) Reactive power due to harmonic voltages superimposed on the fundamental frequency.
- c) Reactive power in excess of nameplate rating due to manufacturing tolerance within the limits specified in 3.1.2.1.

3.1.2.3

Capacitors are capable of continuous operation provided that none of the following limitations are exceeded:

- a) 135% of nameplate kvar (see 3.1.2.2).
- b) 110% of rated voltage rms, and crest voltage not exceeding $1.2 \cdot \sqrt{2}$ of rated rms voltage, including harmonics but excluding transients (see 5.5).
- c) 180% of rated current rms, including fundamental and harmonic currents (see 5.5).

3.1.3 Momentary ratings

Capacitors are capable of withstanding with full-life expectancy switching transients having peak voltages up to $2 \cdot \sqrt{2}$ times rated voltage rms and other transient disturbances inherent in the operation of power systems (see 5.1.2).

3.1.4 Voltage and reactive power ratings

Voltage and reactive power ratings are summarized in table 3.

3.1.5 Insulation classes

The basic impulse insulation levels (BIL) of standard rating capacitors are given in table 3.

3.1.6 Frequency

Power capacitors are designed for operation at a rated nominal frequency of either 50 or 60 Hz.

3.1.7 Ambient temperature

Capacitors are designed for switched or continuous operation in outdoor locations with unrestricted ventilation and direct sunlight under the ambient temperatures for each mounting arrangement shown in table 4.

3.1.7.1 Minimum ambient

Capacitors are designed for continuous operation at -40 °C.

Table 3—Voltage and kvar ratings for 60 Hz capacitors

Volts, rms (terminal-to-terminal)	Kilovar	Number of phases	BIL (kilovolts)
216	5, 7-1/2, 13-1/3, 20, and 25	1 and 3	30*
240	2.5, 5, 7-1/2, 10, 15, 20, 25, and 50	1 and 3	30*
480	5, 10, 15, 20, 25, 35, 50, 60, and 100	1 and 3	30*
600	5, 10, 15, 20, 25, 35, 50, 60, and 100	1 and 3	30*
2 400	50, 100, 150, and 200	1	75
2 770	50, 100, 150, and 200	1	75
4 160	50, 100, 150, and 200	1	75
4 800	50, 100, 150, and 200	1	75
6 640	50, 100, 150, 200, 300, and 400	1	95
7 200	50, 100, 150, 200, 300, and 400	1	95
7 620	50, 100, 150, 200, 300, and 400	1	95
7 960	50, 100, 150, 200, 300, and 400	1	95
8 320	50, 100, 150, 200, 300, and 400	1	95
9 540	50, 100, 150, 200, 300, and 400	1	95
9 960	50, 100, 150, 200, 300, and 400	1	95
11 400	50, 100, 150, 200, 300, and 400	1	95
12 470	50, 100, 150, 200, 300, and 400	1	95
13 280	50, 100, 150, 200, 300, and 400	1	95 and 125
13 800	50, 100, 150, 200, 300, and 400	1	95 and 125
14 400	50, 100, 150, 200, 300, and 400	1	95 and 125
15 125	50, 100, 150, 200, 300, and 400	1	125
19 920	100, 150, 200, 300, and 400	1	125
19 920 [†]	100, 150, 200, 300, and 400	1	125 and 150
20 800 [†]	100, 150, 200, 300, and 400	1	150 and 200
21 600 [†]	100, 150, 200, 300, and 400	1	150 and 200
22 800 [†]	100, 150, 200, 300, and 400	1	150 and 200
23 800 [†]	100, 150, 200, 300, and 400	1	150 and 200
24 940 [†]	100, 150, 200, 300, and 400	1	150 and 200
4160 GrdY/2400	300 and 400	3	75
4800 GrdY/2770	300 and 400	3	75
7200 GrdY/4160	300 and 400	3	75
8320 GrdY/4800	300 and 400	3	75
12 470 GrdY/7200	300 and 400	3	95
13 200 GrdY/7620	300 and 400	3	95
13 800 GrdY/7960	300 and 400	3	95
14 400 GrdY/8320	300 and 400	3	95

*Not applicable to indoor rating.

[†]One bushing.

3.2 Service conditions

3.2.1 Normal service conditions

Capacitors are suitable for operation at their specified rating when

Table 4—Maximum ambient

Mounting arrangement	Ambient air temperature, °C	
	24 h average [*]	Normal annual [†]
Isolated capacitor	46	35
Single row of capacitors	46	35
Multiple rows and tiers of capacitors	40	25
Metal-enclosed or housed equipments	40	25

^{*}The 24 h arithmetic average of hourly readings during the hottest day expected at that location.

[†]As defined in the reports of the U.S. Weather Bureau.

- a) The ambient temperature is within the limits specified in 3.1.7. (Capacitors may be exposed to the direct rays of the sun.)
- b) The altitude does not exceed 6000 ft (1800 m) above sea level.
- c) The voltage applied between terminals does not exceed the rated voltage by more than the tolerance specified in 3.1.2.3.
- d) The voltage applied between terminals and case does not exceed the insulation class specified in 3.1.5.
- e) The applied voltage does not contain harmonics in excess of the limits specified in 3.1.2.3.
- f) The nominal operating frequency is equal to the rated frequency.

3.2.2 Abnormal service conditions

If capacitors are required to operate under abnormal service conditions, such as the following, the application should be brought to the attention of the manufacturer:

- a) Exposure to damaging fumes or vapors
- b) Exposure to conducting or explosive dust
- c) Exposure to abnormal mechanical shock or vibration, including earthquakes
- d) Exposure to radiated heat from surfaces (other than the sun) that are hotter than the ambient temperature limits for capacitors given in 3.1.7
- e) Mounting and/or arrangement that prevents adequate ventilation
- f) Operation in ambient temperatures outside the range specified in 3.1.7
- g) Altitude higher than 6000 ft (1800 m) above sea level
- h) Momentary duty exceeding that listed in 3.1.3
- i) Service conditions other than those listed in 3.2.1

4. Capacitor applications on distribution lines

Shunt power capacitors applied to distribution systems are generally located on the distribution lines or in the substations. This clause deals with those capacitors located on the distribution lines, which may be in pole-mounted racks, pad-mounted banks, or submersible installations. (Substation applications are discussed in clause 5.) The distribution banks often include three to nine capacitor units connected in three-phase

grounded-wye, ungrounded-wye, or delta configurations. Since they are closer to the load, capacitors located on the distribution lines represent a more effective means for supplying the reactive power requirements while minimizing system losses.

The distribution line capacitor banks are either switched or fixed, i.e., not switched. Generally, in determining the type of bank required, consider the following guidelines:

- a) Fixed capacitor banks are sized for minimum load conditions.
- b) Switched capacitor banks are designed for load levels above the minimum condition up to peak load.

The curve shown in figure 3, which can be determined by a recording kilovar meter or calculated using kilowatt and power factor measurements, illustrates a typical kilovar demand over a 24 h period. The fixed banks satisfy the base load requirements, and the switched banks compensate for the inductive kilovar peak during the heavier load periods.

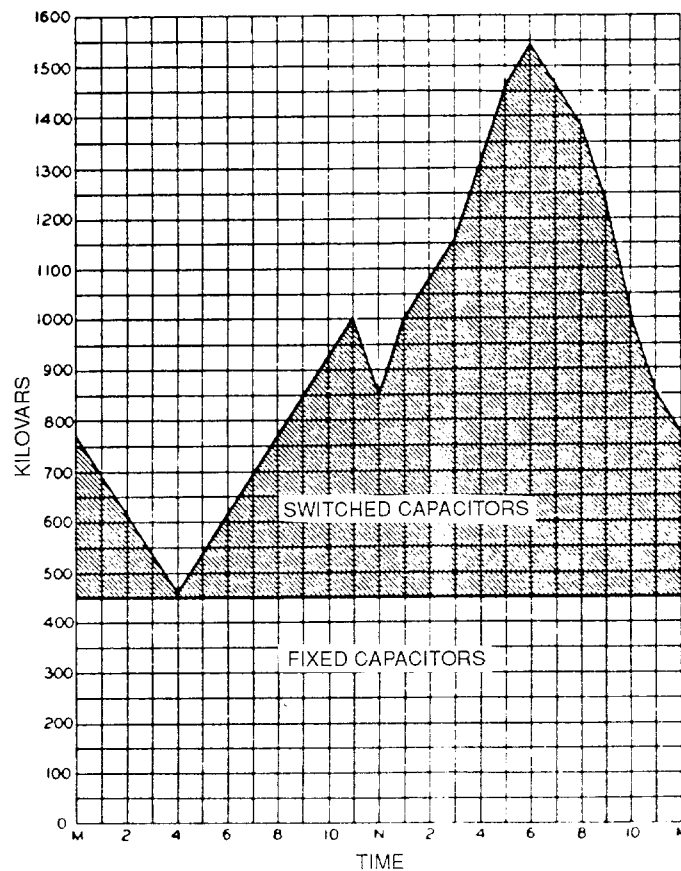

Figure 3—Switching capacitors

4.1 Sizing and locating capacitors

To obtain the optimum benefit of shunt power capacitor applications on the distribution system, the capacitor banks should be located where they produce the maximum loss reduction, provide the maximum voltage benefits, and are as close to the load as possible. When this is not practical, several “rules of thumb” have been utilized for locating capacitors. These include the following:

- a) For uniformly distributed loads, the capacitor should be placed two-thirds of the distance from the substation.
- b) For uniformly decreasing distributed loads, the capacitor should be placed one-half of the distance from the substation.
- c) For maximum voltage rise, the capacitor should be placed near the end of the line.

More specifically, capacitor banks are required at locations where field measurements indicate a low-voltage or low-power factor problem. This information can be obtained as follows:

- a) By making voltage measurements during full-load and light-load conditions at various points on the feeder; and
- b) By making kilowatt and kilovoltampere measurements on the feeder at minimum and maximum daily loads, and during a typical 24 h period.

Once these measurements have been obtained, the equations given in clause 2 can be used to determine voltage rise and kilovar parameters. The capacitor banks may be connected grounded wye, ungrounded wye, or delta. These configurations are discussed in 5.2.

4.2 Switching of capacitors

Switched capacitors give added flexibility to control system voltage, power factor, and losses. Switched capacitors are usually applied with some type of automatic switch control. The control senses a particular condition. If the condition is within a preset level, the control's output level will initiate a close or trip signal to the switches that will either connect or disconnect the capacitor bank from the distribution line. Typical automatic capacitor controls include the following:

- a) *Voltage*. Improvement or control of voltage regulation is a major consideration.
- b) *Current*. When current magnitude is directly related to var demand.
- c) *Var controls*. Where var demand is a major consideration.
- d) *Time switch*. Var demand has a high degree of regularity with respect to time.
- e) *Temperature*. Predictable increase in var demand with temperature change.

Fixed capacitor banks (i.e., not automatically switched) are usually left energized on a continuing basis. However, in areas with significant seasonal demand changes, select banks may be manually switched on a seasonal basis.

Remote switching of capacitor banks is being used in some areas [B6].⁵ This requires a specific capacitor bank or group of banks to have controls capable of receiving a signal and initiating a close or open operation on the capacitor switches. The computer algorithm or manually entered command originates at a remote location.

Typical media for remote switching of capacitor banks include the following:

- a) *Radio*. When the area allows appropriate radio frequency to be transmitted without much interference.
- b) *Power line carrier*. Appropriate line coupling equipment is required, usually at the substation.
- c) *Telephone*. Over leased or private telephone lines.

⁵The numbers in brackets preceded by the letter B correspond to those of the bibliography in clause 8.

4.3 Switchgear ratings

Switchgear applied to a capacitor rack should be rated for that specific duty. The key considerations are continuous current, inrush current during energization, nominal system voltage, and transient recovery voltage during de-energization. These parameters are defined in more detail for circuit breakers in IEEE Std C37.06-1987 and IEEE Std C37.012-1979. These standards suggest using a continuous current rating for the breaker that is 1.25 times the nominal capacitor current at rated capacitor voltage for ungrounded neutral operation and 1.35 times the nominal current for grounded neutral operation. Inrush current duties are defined in terms of peak magnitude and frequency.

Capacitor switches must also be capable of withstanding inrush current, which, for an isolated bank, is as follows:

$$I_{pk} = 1.41 \sqrt{I_{SC} \cdot I_1}$$

where

- I_{pk} is the peak value of inrush current, in amperes
- I_{SC} is the available three-phase fault current, in amperes
- I_1 is the capacitor bank current, in amperes

When switched racks are close together, inrush currents may be a concern for the switching device. When one bank is energized, the switching “on” of the second bank can result in an inrush current into the second bank due to the discharging of the capacitors from the already energized first bank. The inrush current magnitude and frequency can be calculated as follows:

$$I_{pk} = 1747 \cdot \sqrt{\frac{V_{LL}(I_1 \cdot I_2)}{L_{eq}(I_1 \cdot I_2)}} \quad (\text{for } f_s = 60 \text{ Hz})$$

$$f_t = 9.5 \cdot \sqrt{\frac{(f_s)(V_{LL})(I_1 + I_2)}{L_{eq}(I_1 \cdot I_2)}}$$

where

- f_s is the system frequency, in hertz
- f_t is the frequency of transient inrush current, in kilohertz
- L_{eq} is the total equivalent inductance per phase between capacitor banks, in microhenries
- I_1, I_2 are the currents of bank being switched and of bank already energized, respectively, in amperes. Capacitor bank being switched is assumed uncharged, with closing at a voltage crest of the source voltage. The current used should include the effect of operating the capacitor bank at a voltage above nominal rating of the capacitors and the effect of a positive tolerance of capacitance. In the absence of specific information, a multiplier of 1.15 times nominal capacitor current would give conservative results.
- I_{pk} is the peak value of inrush current calculated without damping, in amperes. In practical circuits, it will be about 90% of this value.
- V_{LL} is the rated maximum line-to-line voltage, in kilovolts

Several hundred feet between overhead capacitor banks is usually an adequate separation distance to limit the inrush current to an acceptable level, but configurations where the banks are very close together may require inrush current limiting reactors.

When switching is done at nominal system voltage, the switch recovery voltage reaches 2.0 per unit for a grounded-wye-connected bank and 2.5 per unit for an ungrounded-wye bank. Under some conditions the recovery voltage can reach 4.1 per unit for an ungrounded-wye bank (see 5.3.2.1 for details). The initial voltage across the interrupter contacts following the breaking of a capacitive circuit is practically zero since the capacitor on the load side of the switch holds the same instantaneous voltage as existed on the supply side. Usually, the capacitive circuit is not broken until its current is zero. At this time, the voltage of the circuit and capacitor are at a maximum and of the same value. One-half cycle later, the voltage across the switch contacts is twice the crest value of the fundamental (for a grounded-wye bank) since the capacitor has retained its charge and the supply voltage has reached its crest of the opposite value, as shown in figure 4.

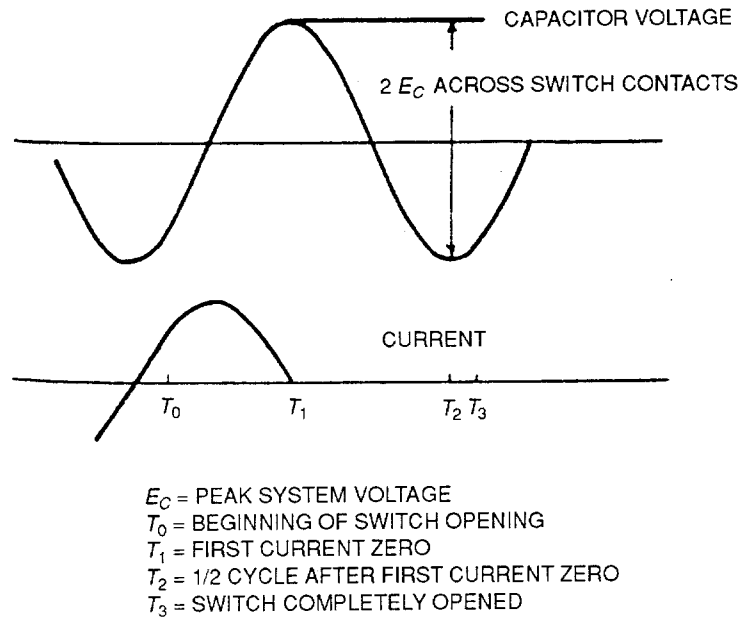

Figure 4—Switch recovery voltage

A more detailed discussion of the concerns associated with capacitor switching is given in 5.3.

4.4 Protection

Due to the relatively small size of capacitor banks used in distribution feeder applications, the protection methods are generally less complex and comprehensive than those used for substation banks (see 5.6 for substation applications). The protection of pole-mounted racks includes capacitor fusing and surge arresters.

4.4.1 Fusing

In distribution capacitor banks, group fusing, individual capacitor unit fusing, or a combination of the two may be used. Group fusing involves the use of a single fuse in series with all of the capacitors in that phase. For individual fusing, each capacitor unit is fused separately (see 5.6.1). Group fusing is the most commonly used method in this type of distribution line application.

Individual unit fusing is generally not used on small ungrounded-wye banks due to overvoltage stress on units adjacent to a unit isolated by a fuse operation. The function of the group fuse is to detect the escalating failure of a single capacitor and remove the capacitor group from service fast enough to prevent case rupture and damage to other units. At the same time, it is desirable that the group fuse withstand the normal capacitor bank operating conditions without spurious fuse operations.

To withstand normal conditions, it is necessary that the group fuse be sized to withstand the following conditions:

- a) *Continuous current.* This includes consideration for a harmonic component, capacitance tolerance (maximum of +15%), and overvoltage (+10%). Historically, the continuous current capability of the fuse has been a minimum of 125% to 135% of the capacitor nominal current.
- b) *Switching inrush current.* Although this is seldom a concern for pole-mounted banks (except in cases where they are very close together), the “minimum-melting” curve of the fuse should be coordinated with the bank inrush current to minimize the possibility of nuisance fuse operations.
- c) *Surge current.* The surge current due to a lightning stroke or a nearby arcing fault can be a significant concern for pole-mounted capacitor banks especially for the lower amperage rated fuses. In high lightning incidence areas, slower fuse speeds with higher surge withstand capability (e.g., T-speed) are often used rather than faster fuse speeds (e.g., K-speed) for the lower amperage rated fuses.
- d) *Rated fuse voltage.* The group fuse is rated for phase-to-phase voltage for ungrounded-wye banks and phase-to-ground voltage for grounded-wye banks applied on solidly grounded neutral (multi-grounded) systems, provided that BIL rating and leakage distance to ground of the fuse mounting are sufficient for the application. The higher voltage is needed for ungrounded-wye banks due to the higher recovery voltage across the fuse when clearing a failed unit.

To minimize the possibility of case rupture of the failed unit and damage to other units, the fuse should be selected to

- a) *Interrupt the maximum 60 Hz fault current expected.* In grounded-wye and delta-connected applications, the maximum current is the system available fault current at the capacitor location. The withstand capability of each capacitor varies with design and size, so the available fault current at each location should be compared with the capacitor case rupture curve, which is available from each manufacturer. If the short-circuit current is excessive, other options available include the utilization of current-limiting fuses to limit the fault current, connecting the bank in ungrounded-wye which will significantly reduce the fault current, or moving the bank to another location with an acceptably lower available fault current. (It should be noted that when the bank is connected in an ungrounded-wye configuration, a phase-to-ground fault may still occur if the capacitor tank is grounded. However, the failure of the major insulation from the internal capacitor pack to the capacitor case is rare.)
- b) *Coordinate with the capacitor case rupture curve for each capacitor unit.* The “maximum total clearing” curve of the fuse to be used must lie to the left of the case rupture curve. A typical capacitor case rupture curve is given in figure 5.
- c) *Remove the failed unit without impressing excessive over-voltages on good units.* In ungrounded-wye applications, line-to-line voltage will be impressed on the good phases during the shorting of a capacitor unit. The permissible overvoltages are summarized in table 6 of 5.1.2. This table indicates a desired clearing time of less than 1 s. This is generally difficult to achieve in a group-fused ungrounded-wye application since the available fault current is only three times the normal capacitor bank phase current. Good performance has generally been achieved by selecting the fastest clearing fuse that meets the continuous current, switching inrush current, and lightning surge current requirements discussed previously. Generally, clearing times on the order of 15 s to 2 min can be achieved for a completely failed unit with three times the normal phase current flowing.

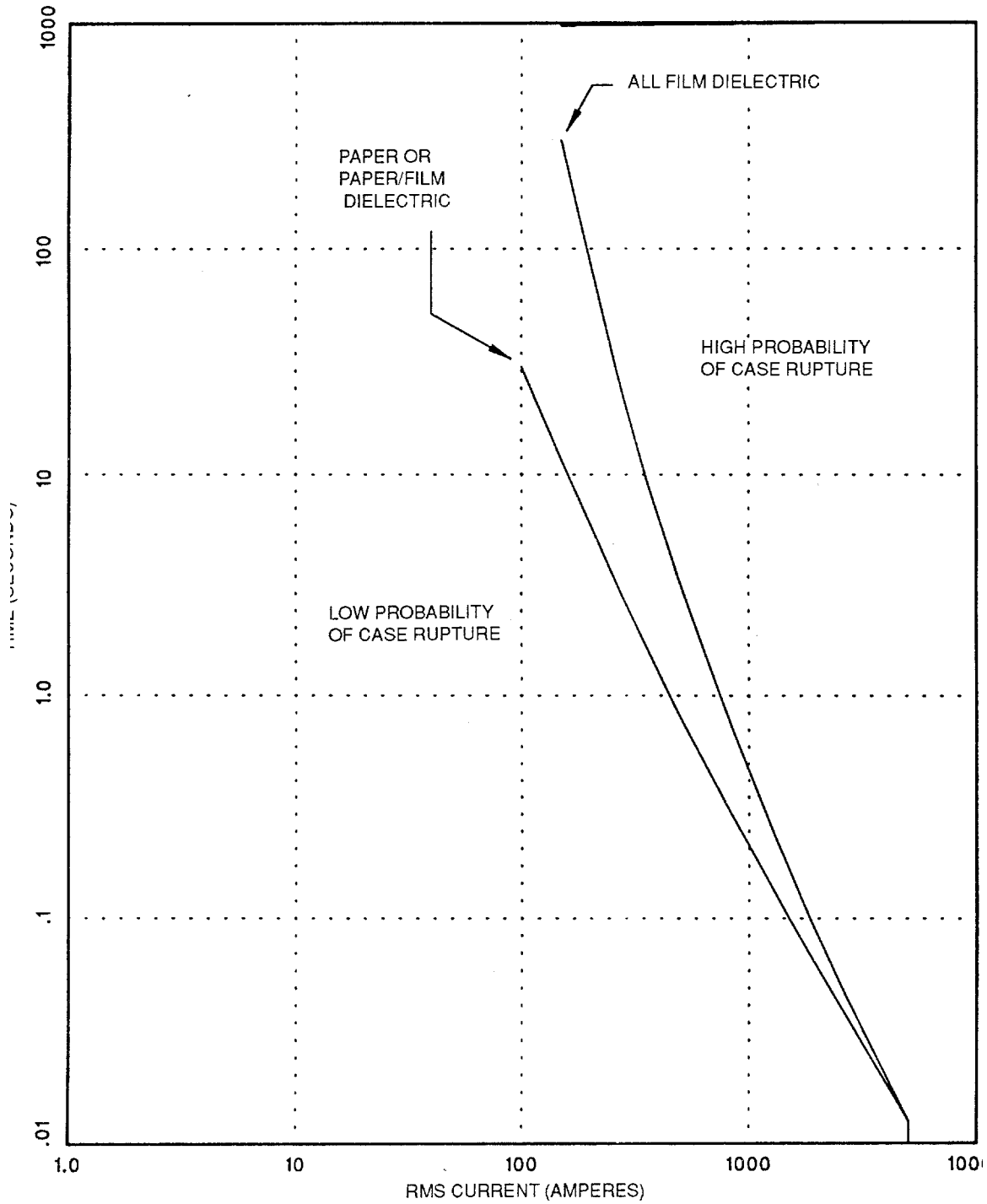

Source: NEMA CP 1-1988. Reproduced by permission of the National Electrical Manufacturers Association who holds copyright for that publication.

Figure 5—Typical case rupture curves for approximately 1800 in³ case volume

In some applications, it may be difficult to meet all of these objectives. In such cases, trade-offs among the criteria are necessary.

4.4.2 Surge arresters

Lightning surges and the switching of capacitors can result in significant system overvoltages. Surge arresters may be applied at the capacitor bank to limit these transient overvoltages (see IEEE Std C62.2-1987). Restrikes in the switching device can cause the highest transients. Significant transient overvoltages can also occur at the capacitor bank due to surge magnification of resonant circuits on the power system associated with switching of a remote capacitor bank, cable, or transmission line [B19] (see 5.3.1.3 for more detailed information).

Generally, arresters are installed on the system side of the capacitor fuse, and as close as possible to the capacitor bank. The connections should be kept as short as possible, in order that the voltage stress upon capacitor unit insulation is minimized. Placing the arrester on the source side of the fuse reduces the surge current through the fuse. This is most important for small capacitor banks on high-voltage systems where fuse sizes of less than 15 A are common.

4.5 Harmonic considerations

Harmonic problems may result in blown fuses, failed capacitor units, damaged control transformers, and misoperating relays. Although transformers can be a major harmonic producer on distribution systems, devices that utilize arcs (arc furnaces, arc welders) or electronic power converters (computers, variable speed motors, dc motors, chemical processes, uninterruptible power supplies) have become significant harmonic sources on some feeders. With the rise of dispersed generation and storage (DSG) on distribution systems, as well as the widespread use of electronic power converters for other uses, a harmonic problem should be considered—and investigated—in the event of unexplained bank equipment failure or malfunction. IEEE Std 519-1992 recommends a voltage total harmonic distortion (THD) limit of 5.0% for general power systems up to 69 kV.

The usage of shunt power capacitors to improve system operating efficiencies also has a significant influence on harmonic levels. Capacitors do not generate harmonics, but provide a network path for possible local or general resonance conditions. Even though capacitors do not generate harmonics, they can influence the magnitudes of harmonic voltages and currents that occur on the utility system as well as the customer loads.

If harmonic problems are discovered through analysis or experience, possible solutions include the following:

- a) Ungrounding grounded-wye capacitors.
- b) Changing capacitor bank sizes and/or locations.
- c) Adding a reactor to an existing capacitor bank.
- d) Adding a filter capacitor.
- e) Controlling the capacitor switching scheme to avoid resonance.

A more detailed evaluation of applying capacitors in a harmonic environment is given in 5.5.

5. Substation shunt power capacitor bank applications

This clause describes the considerations for applying shunt power capacitor banks in a substation environment. It includes both distribution and transmission system applications. It does not include distribution line applications, which are discussed in clause 4.

5.1 Size and number of banks

The shunt capacitance requirements are determined by optimizing the benefits described in clause 2 for a given set of system requirements. Distribution substation capacitors are often sized to supply the var requirements of the load supplied by the substation transformer bank(s). This provides for power factor correction to unity at the high side of the transformers and effective operation of the transmission or subtransmission system. Transmission substation capacitors are often sized and located based on load flow and stability studies of the transmission network. The capacitors minimize system losses, increase the system voltage, and increase stability margins. After the var requirements are known, the individual capacitor bank megavar sizes and number of steps are determined. To take advantage of the economies associated with standardized equipment, other limitations may influence the maximum and minimum capacitor bank sizes used.

5.1.1 Maximum size

The maximum bank size is influenced by the following factors:

- a) Change in system voltage upon capacitor bank switching.
- b) Switchgear continuous current limitations.

When a capacitor bank is energized or de-energized, the fundamental system voltage increases or decreases, respectively. In order to have a minimal effect upon customer loads, this voltage change is often limited to a value in the range of 2% to 3%. This voltage change (ΔV) can be estimated by the following formula:

$$\Delta V = \left(\frac{Mvar_{min}}{MVA_{SC}} \right) \cdot 100\%$$

where

- $Mvar$ is the Mvar size of the capacitor bank
 MVA_{SC} is the available three-phase short-circuit MVA at the capacitor bank location

The continuous-current rating of switchgear used for capacitor bank switching may be a factor in choosing the capacitor bank size. The rating is usually determined by multiplying the nominal capacitor current by 1.25 for ungrounded operation and by 1.35 for grounded-wye banks. More detailed information is available in IEEE Std C37.04-1979, ANSI C37.06-1987, and IEEE Std C37.012-1979.

5.1.2 Minimum size

The minimum bank size is influenced by the following factors:

- a) Capacitor bank unbalance considerations
- b) Fuse coordination

When a capacitor fuse operates to indicate a failed capacitor, an unbalanced condition can occur that subjects units in the same series group to a 60 Hz overvoltage. A common criteria is to limit this overvoltage to 110% with one unit out. This requires a minimum number of units in parallel as given in table 5 (taken from table 2 of IEEE Std C37.99-1990).

When a capacitor is completely shorted, other series groups within the capacitor bank are subject to a 60 Hz overvoltage until the fuse clears. The fuse should clear fast enough so as not to damage the good units due to this overvoltage. IEEE Std 18-1992 indicates that, "a capacitor may reasonably be expected to withstand, during normal service life, a combined total of 300 applications of power frequency terminal-to-terminal

overvoltages without superimposed transients or harmonic content, of the magnitudes and durations” shown in table 6.

Table 5—Minimum recommended number of units in parallel per series group to limit voltage on remaining units to 110% with one unit out

Number of series groups	Grounded Y or Δ	Ungrounded Y	Split ungrounded Y (equal sections)
1	—	4	2
2	6	8	7
3	8	9	8
4	9	10	9
5	9	10	10
6	10	10	10
7	10	10	10
8	10	11	10
9	10	11	10
10	10	11	11
11	10	11	11
12 and over	11	11	11

Table 6—Maximum permissible capacitor voltage

Duration	Maximum permissible voltage (multiplying factor to be applied to rated voltage rms)
6 cycles	2.20
15 cycles	2.00
1 s	1.70
15 s	1.40
1 min	1.30

When a capacitor unit is shorted on phase A, the 60 Hz voltages on the other series groups in the bank are summarized in table 7.

The values in tables 6 and 7, coupled with the fuse size being used, will indicate the minimum number of capacitor units to be used. The capacitor bank should be designed such that the duration of the overvoltages defined in table 7 do not exceed the times defined in table 6. The factors that influence this design include the bank connection, the number of series groups, the number of parallel units, and the fuse characteristic.

Table 7—Per unit voltage on good capacitors

No. of series groups	Grounded Y or Δ			Ungrounded Y			Split ungrounded Y		
	V_a	V_b	V_c	V_a	V_b	V_c	V_a	V_b	V_c
1	—	1.00	1.00	—	1.73	1.73	—	1.73	1.73
2	2.00	1.00	1.00	1.50	1.15	1.15	1.71	1.08	1.08
3	1.50	1.00	1.00	1.29	1.08	1.08	1.38	1.04	1.04
4	1.33	1.00	1.00	1.20	1.05	1.05	1.26	1.03	1.03
5	1.25	1.00	1.00	1.15	1.04	1.04	1.20	1.02	1.02

5.2 Bank configurations

There are three basic capacitor bank configurations: grounded wye, ungrounded wye, and delta. Delta-connected capacitors are generally only used at low voltages, e.g., 2400 V, where a standard capacitor rating is not available for a wye connection. Usually, wye-connected capacitor installations are less complicated to construct and more economical.

There are certain advantages and disadvantages associated with grounded-versus-ungrounded-wye capacitor banks. The advantages of the grounded-wye arrangement compared to the ungrounded wye are as follows:

- a) Initial cost of the bank may be lower since the neutral does not have to be insulated from ground at full system BIL, as in the case with floating neutral arrangements.
- b) Capacitor switch recovery voltages are reduced.
- c) Mechanical duties (e.g., seismic) may be less severe for the structure.

The disadvantages of the grounded-wye arrangement compared to the ungrounded wye are as follows:

- a) High inrush currents may occur in station grounds and structures, which may cause instrumentation problems.
- b) Grounded neutral may draw zero-sequence harmonic currents and cause telephone interference.
- c) The grounded-wye arrangement provides a low-impedance fault path to ground and may require resetting of ground relays on the system. This is one reason why grounded-wye banks are not generally applied to ungrounded systems.
- d) In banks with one series group, the grounded-wye arrangement usually makes current-limiting fuses necessary because of the line-to-ground fault magnitudes.

Grounded-wye, ungrounded-wye, and delta-connected capacitors may be subject to ferroresonant overvoltages if they are switched together with transformer banks of certain winding connections with single-pole switching devices or if a stuck pole should occur on a three-phase device. For the ungrounded capacitor, if the transformer has a grounded neutral or even if it consists of many single-phase transformers applied about equally along the feeder, a potentially ferroresonant circuit exists if single-phase switching devices are operated upstream. Both transformers and surge arresters have failed under these conditions. If the transformer is three-phase ungrounded, then the grounded capacitor bank should be avoided for the same reason. Although ferroresonance can and does occur on these circuits, it occurs only rarely because resistive load on the transformers can prevent its occurrence.

On ungrounded or uni-grounded systems, only ungrounded-wye and delta capacitor bank configurations are used. On solidly grounded systems, grounded-wye, ungrounded-wye, and delta configurations may be used.

5.3 Capacitor bank switching

When a capacitor bank is energized or de-energized, current and voltage transients are produced that affect both the capacitor bank and the connected system. (Switchgear rating considerations are discussed in 4.3.)

5.3.1 Energization

5.3.1.1 Energizing an isolated bank

Figure 6 shows an equivalent circuit for energizing an isolated capacitor bank from a predominantly inductive source. When the switch is closed, a high-frequency, high-magnitude current flows into the capacitor, attempting to equalize the system voltage and the capacitor voltage. If the switch is closed at a voltage peak, the voltage on the capacitor attempts to immediately increase from the zero-voltage, de-energized condition to the peak voltage. In the process of achieving this voltage change, an overshoot occurs, equal to the amount of the attempted voltage change. This voltage surge is also of the same high frequency as the inrush current, and rapidly decays to the system voltage. The magnitude of the voltage surge, for an isolated grounded-wye capacitor bank, is a maximum of 2.0 per unit. (More typically, the maximum is on the order of 1.8 per unit as shown in figure 7.)

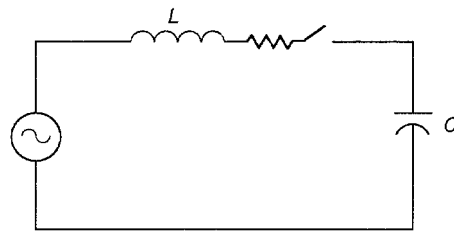

Figure 6—System diagram for energizing an isolated capacitor bank

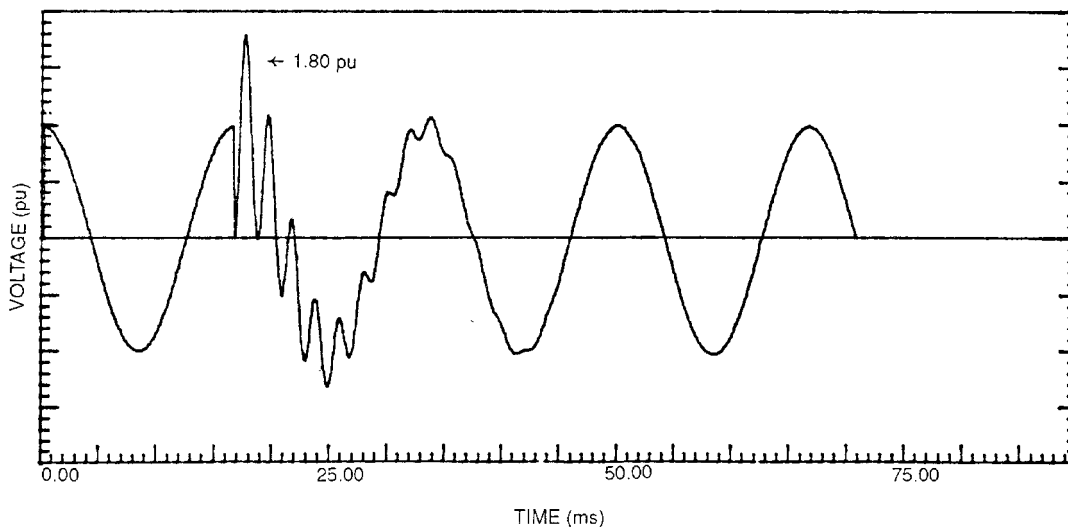

Figure 7—Bus voltage for capacitor bank energization

Energizing an ungrounded-wye capacitor bank can result in slightly higher transient overvoltages because of unequal pole closing. In general, the transient overvoltages associated with normal closing are similar to those for grounded-wye banks.

5.3.1.2 Dynamic overvoltages

Energizing a transformer and a capacitor bank together (figure 8) can cause excessive dynamic overvoltages that affect the transformer, the capacitors, the fuses, and the arresters. These overvoltages may be evidenced by capacitor failures and/or spurious fuse operations.

The nature of the problem involves generation of high voltages due to the transformer inrush currents that are rich in harmonics by a system whose natural frequency is near one of these harmonics. Transformer inrush current includes significant magnitudes of harmonics of the fundamental frequency, i.e., second, third, fourth, fifth, etc. The highest magnitudes tend to occur for the lowest order harmonics. If the system equivalent impedance at one or more of those frequencies is high, then the voltage at the point will also be high ($V = IZ$). This tends to happen when a shunt power capacitor bank is applied, causing a parallel resonance with the system. The problem exhibits itself in the form of a long-term overvoltage, which has a high harmonic content, lasting for many cycles—even seconds (see figure 9).

Because arresters cannot effectively protect against steady-state or dynamic overvoltages, switching transformers and capacitor banks together is not recommended unless detailed studies show that the resulting overvoltages will not be excessive. This type of switching is commonly done on distribution circuits where the resistive component of the load usually effectively dampens this type of transient.

5.3.1.3 Voltage magnification

When more than one capacitor bank is involved in the circuit at different voltage levels, voltage magnification can occur [B19]. Magnification of the voltage surge normally takes place on an inductively coupled low-voltage system when a capacitor is switched on a high-voltage system. Figure 10 illustrates a system on which this phenomenon might occur.

Figure 11 shows the equivalent circuit. There are two coupled inductive-capacitive circuits. If the resonant frequencies of these two loops are approximately the same, i.e., $L_1 \cdot C_1 = L_2 \cdot C_2$, voltage magnification can occur because the lower voltage circuit is being injected with a voltage source at its own resonant frequency. The voltage magnitude is intensified when the switched capacitor is much larger than the fixed capacitor on the low-voltage system, i.e., $C_1 \gg C_2$ and $L_1 \ll L_2$. Figure 12 illustrates a representative simulation of this phenomenon. These voltage magnitudes are high enough to spark over distribution arresters on the low-voltage system.

This voltage magnification may be evidenced by failed equipment and arresters at remote locations during capacitor switching. The problem can usually be remedied as follows:

- a) Detuning the circuit by changing capacitor bank sizes or moving banks.
- b) Using preinsertion resistors on breakers to limit voltage surge magnitudes.
- c) Ungrounding the remote bank.
- d) Switching large banks in more than one section [B19].

The reason for concern with regard to this problem is that capacitor switching is often a daily event. Repetitive surges of high magnitude may eventually damage equipment and may result in severe arrester duty.

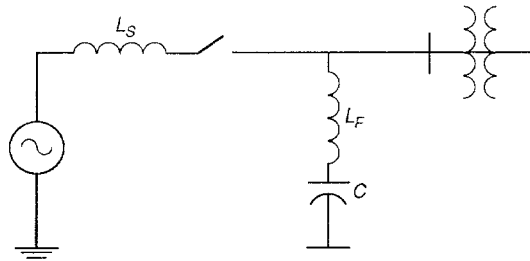

Figure 8—System diagram for dynamic overvoltage condition

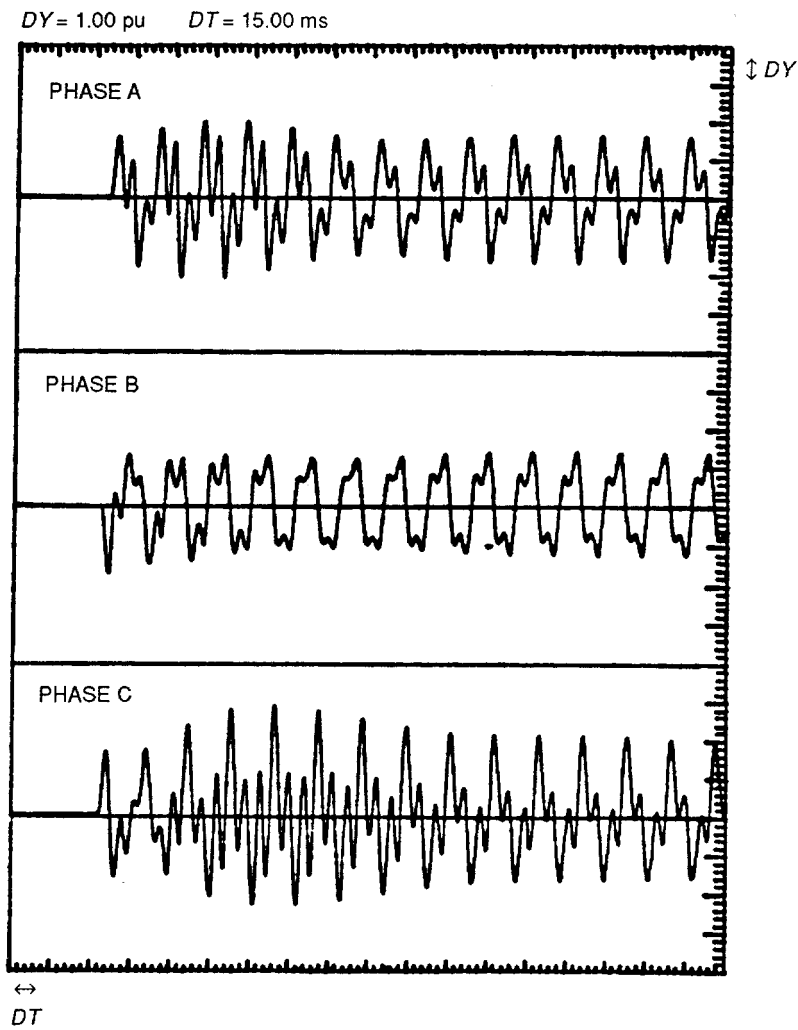

Figure 9—Dynamic overvoltage on filter capacitors

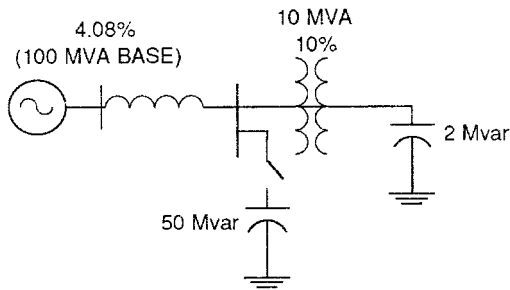

Figure 10—System diagram for magnification condition

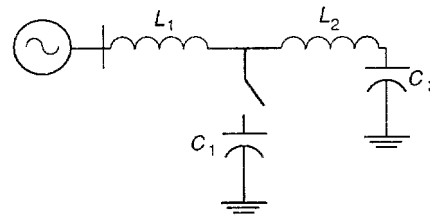

Figure 11—Equivalent circuit for magnification condition

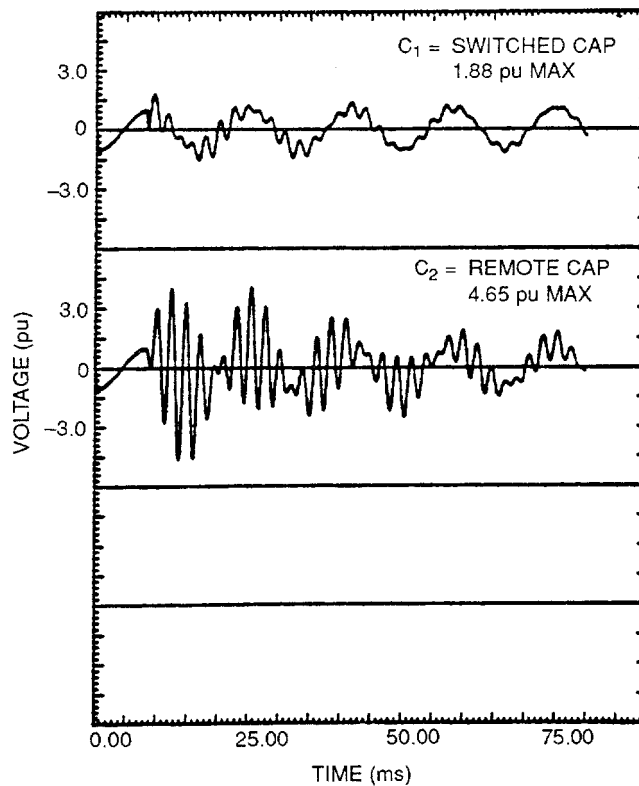

Figure 12—Magnification of transient at remote cap bank

5.3.1.4 Phase-to-phase insulation

The energization of a shunt power capacitor bank may subject other system equipment to excessive phase-to-phase overvoltages, especially delta-connected transformers. A potential problem system is illustrated in figure 13.

Surges generated by the energization of the capacitor bank would travel down the line towards the transformer and double at that point. It would be possible to get a +2.0 per unit surge on one phase and a -2.0 per unit on another. This would result in 4.0 per unit phase-to-phase. (Voltages are given in per unit of the rated

peak line-to-ground voltage.) This could be a potential problem for transformers that are applied in this configuration (see [B8]). A typical example of this type of transient is shown in figure 14. The actual severity of the transient is a function of the system configuration and can be significantly higher than the 4.0 per unit value mentioned above. In general, this transient can be reduced by any of a number of methods including closing resistors, controlled closing, staggered closing, capacitor bank reactors, and surge arresters [B3].

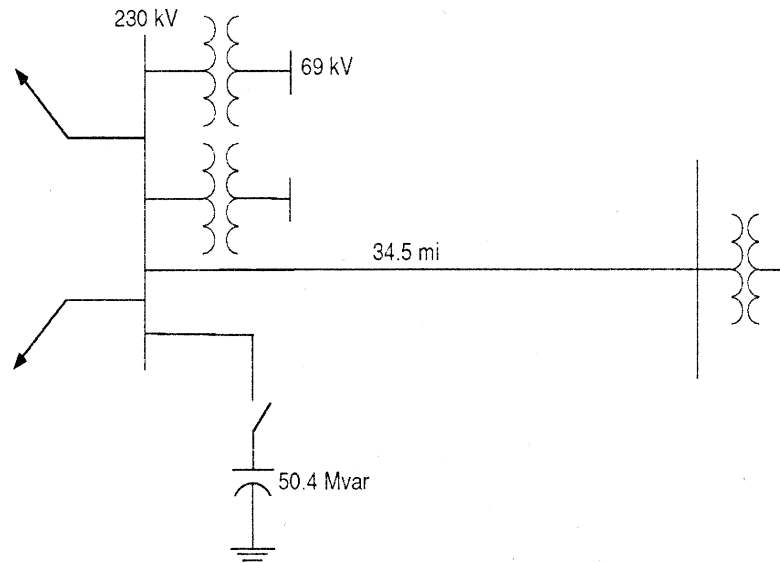

Figure 13—System diagram for transient shown in figure 14

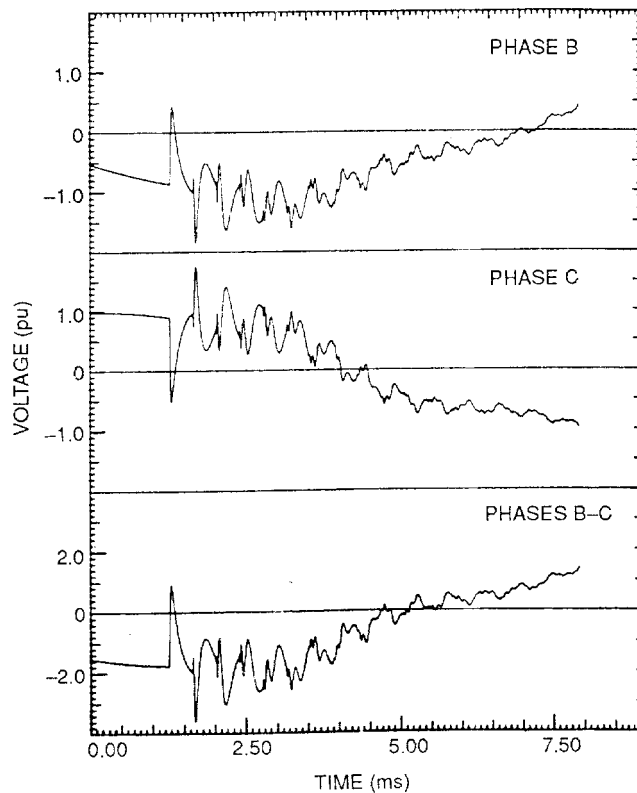

Figure 14—Field measurement of transformer transient due to capacitor switching

5.3.1.5 Prestrike

Prestrike may occur during the energization of a bank. When the bank is energized, an arc is established within the interrupters before the contacts physically make contact. This phenomenon is called *prestrike*. When a prestrike occurs, normal high-frequency inrush current flows. Certain interrupters can interrupt this high-frequency current at a high-frequency current zero. When the interrupter again strikes the arc, transient voltages and currents occur due to the trapped charge on the capacitor. The level of concern for this phenomenon is a function of the time delay before it strikes again and the number of times that it occurs [B18].

5.3.1.6 Energization of back-to-back capacitor banks

When a capacitor bank is energized in near proximity to a previously energized capacitor bank, further considerations arise. A high-frequency inrush current flows when the bank is energized. However, the limiting inductance is the inductance between the banks rather than the system inductance. The magnitude and frequency of this inrush current is, therefore, much higher than the inrush to an isolated bank (see IEEE Std C37.012-1979). See 4.2 for equations to calculate inrush currents for back-to-back switching of substation capacitor banks. These equations can also be used for computing of inrush currents when more than two banks are switched back-to-back provided the equivalent inductance is calculated properly.

This high-frequency inrush may exceed the transient frequency momentary capability of the switching device (see ANSI C37.06-1987) as well as the I^2t withstand of the capacitor fuses. It may also cause false operations of protective relays and excessive voltages for current transformers in the neutral or phase of grounded-wye capacitor banks.

Back-to-back switching is typified by the circuit shown in figure 15. The magnitude and frequency of the inrush current is determined to ensure the proper operation of the switching device as well as relays, fuses, etc. Where inrush currents are excessive, one or a combination of the following steps is taken:

- a) Add current limiting reactors to decrease the peak current and frequency of the oscillatory inrush transients.
- b) Add switch preinsertion resistors. These resistors are designed to over-damp the circuit, preventing oscillations and allowing the capacitor to become essentially charged to line potential before the main contacts of the switch close.
- c) Switch the capacitor in smaller megavar increments.
- d) Control the switching device to close on zero voltage difference across the switch.

To control the substation ground mat transients due to the high-frequency inrush currents, where two or more grounded wye banks are at the same location, the bank neutrals may be directly connected, with a single connection to ground. (See IEEE Std C37.99-1990 for more details.)

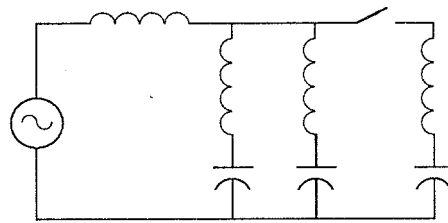

Figure 15—Back-to-back switching circuit

5.3.2 De-energization

5.3.2.1 Restrike

A capacitor switching device de-energizes a capacitor bank at current zero. Since the current is strictly capacitive, the voltage at that time is at a peak. The initial interruption of a capacitive circuit is generally very easy duty since the current magnitude is quite low compared to fault currents. The current may, therefore, be interrupted when the interrupter contacts have parted only a small amount. In addition, the capacitor traps the peak voltage on the load side of the switch, and the instantaneous voltage on the source side of the switch is of the same polarity. Figure 16 illustrates this phenomena for a grounded-wye bank.

Successful interruption depends on whether the interrupter can build up sufficient dielectric strength to withstand the rate of rise and the peak of the recovery voltage. One-half cycle after interruption on a grounded-wye bank, two times system voltage appears across the contacts. If restrike occurs at this point, the capacitor attempts to recover to crest voltage of the opposite polarity and, in doing so, over-shoots by the amount of the attempted correction. The current waveform is the oscillatory inrush. If this inrush is interrupted at a high-frequency current zero, as much as 3 per unit voltage may be trapped on the capacitor, and the restriking process may continue with the subsequent buildup of even higher voltages.

Ungrounded-wye banks subject the capacitor switching device to even higher recovery voltages than the 2.0 per unit observed for grounded-wye banks:

- a) 2.5 per unit on the first phase to open when the other two phases open on the next current zero
- b) 3.0 per unit on the first phase to open when the other two phases delay opening
- c) 4.1 per unit on the first phase to open when one of the other two phases delays opening

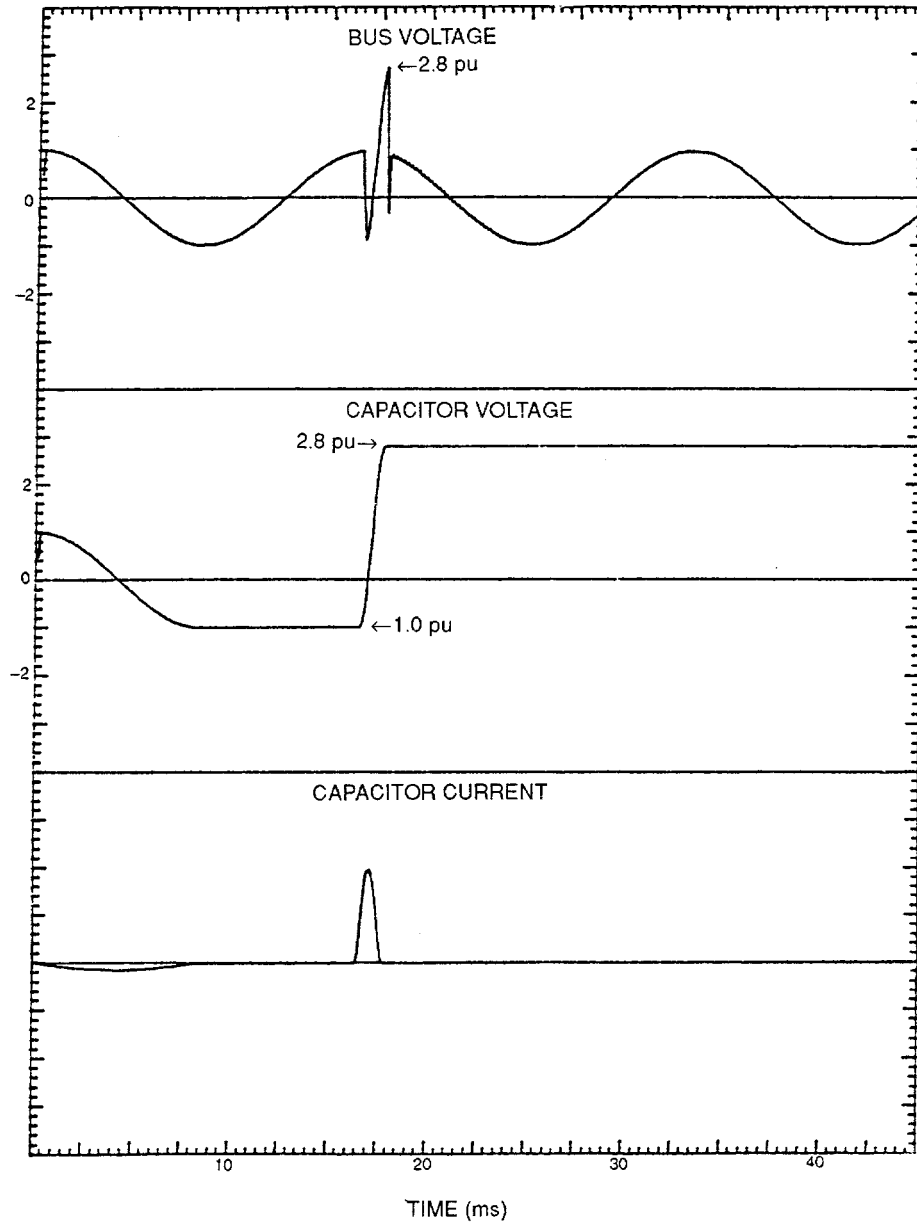

Figure 16-De-energizing capacitor bank with restriking switching device

Restriking capacitor bank switching devices can result in high system voltage surges that may result in severe arrester energy duty or equipment damage if not protected adequately. Therefore, it is desirable to choose a switching device that will minimize the possibility of restrike. If restriking is expected, it is desirable to protect the equipment with the appropriately sized arresters [B13]. The arrester may be analyzed based upon the energy associated with a restrike. If the standard arrester energy capability could be exceeded, a high-energy-capability arrester with a lower overvoltage protective level may be applied at the capacitor bank.

5.3.2.2 Fault clearing

Faults within a capacitor bank may be cleared either by the dedicated switch for the capacitor bank or by another switching device in the substation. In either case, the switch must be able to handle the recovery voltage and the capacitive switching current that will occur on the unfaulted phases during a fault clearing event. This is of special concern for circuit breakers that may be used to clear fault currents, but that may not be rated for capacitance switching duty. (See IEEE Std C37.012-1979 for additional details.)

5.4 Outrush current

The outrush current from large capacitor banks is a concern for a breaker closing into a nearby fault [B12]. The result is that a high-frequency, high-magnitude current may flow in a breaker that is not rated for that duty. In ANSI C37.06-1987 switchgear inrush current limitations are defined. These inrush limitations are also applied to the outrush considerations.

The circuit of concern for the outrush calculations is illustrated in figure 17 for a single capacitor bank. The limiting criterion is sometimes the $I_{pk} \cdot f$ product. (See notes for tables 1A, 2A, and 3A in ANSI C37.06-1987.) It is interesting to note that this product is independent of capacitor size. In other words, the required series inductance is dependent only on the peak voltage when the breaker closes into the fault (see equations in figure 18).

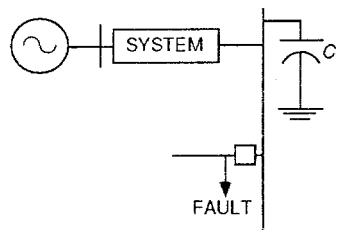
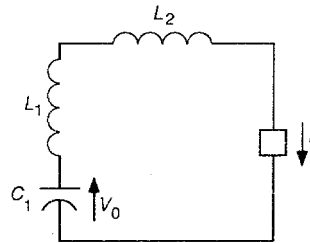

Figure 17—System diagram for outrush current condition



EQUATIONS:

$$f = \frac{1}{2\pi\sqrt{L_{eq}C_1}}$$

$$I_{pk} = V_0\sqrt{\frac{C_1}{L_{eq}}}$$

$$I_{pk} \cdot f = \frac{V_0}{2\pi L_{eq}}$$

WHERE

V_0 = INITIAL VOLTAGE ON C_1

L_1 = SELF-INDUCTANCE OF C_1

L_2 = INDUCTANCE BETWEEN CAP AND FAULT

L_{eq} = $L_1 + L_2$

Figure 18—Equivalent circuit for outrush current calculation

Closing resistors do not affect the outrush current magnitude or frequency. The full outrush current occurs when the resistors are bypassed.

With a parallel capacitor bank, there are a number of different ways to configure the capacitors and required series reactors. A few of the options are indicated in figure 19. Each option has advantages and disadvantages.

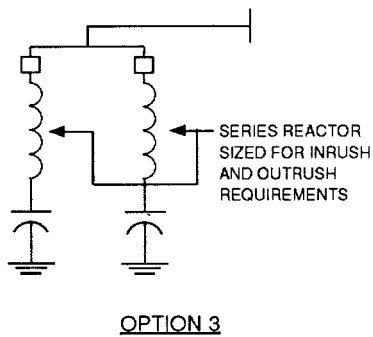
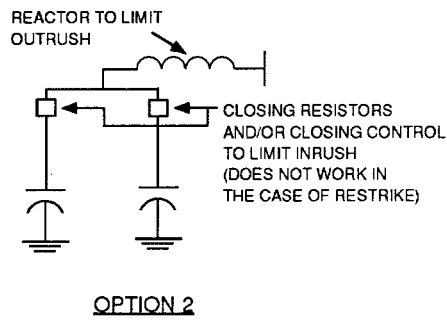
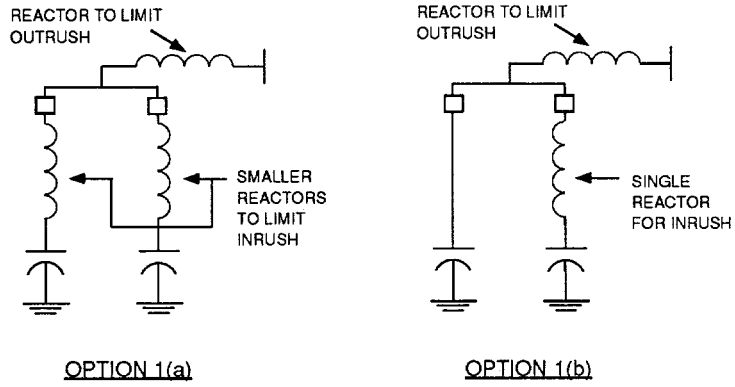

Figure 19—Current limiting reactor options with parallel banks

Option 1: Separate reactors for inrush and outrush requirements. When a larger reactor is needed for outrush, a common reactor for limiting outrush current, in addition to smaller reactors for inrush current limiting, may be the optimum configuration. An alternate configuration for this scheme is shown in Option 1(b) of figure 19. This alternate configuration has the advantage of only requiring two reactors, while still accomplishing the objectives of controlling both inrush and outrush currents.

Option 2: Reactor for outrush only, breakers limit inrush. If inrush current for back-to-back switching can be limited to acceptable levels without current-limiting reactors, this is probably the most economical configuration. Closing resistors or a closing control to close the contacts near voltage zeros are common alternate methods to limit the inrush current. The single reactor is used to limit outrush currents to acceptable levels. A disadvantage of this option is the high-current magnitude and frequency that can occur in the event of a restrike on opening.

Option 3: Series reactors sized for inrush and outrush in series with each capacitor bank. If the reactor cost is not significantly dependent on its millihenry size, then this option may be more economical than Option 1. However, with two equal capacitor banks in parallel, the reactor millihenry value required to control outrush may be more than double the single bank size.

5.5 Harmonics

The levels of harmonic voltage and current on power systems are increasing. One important reason is the proliferation of devices that produce harmonics; solid-state power conversion devices are prime examples. These devices find uses at wide ranges of power levels industrially, commercially, and in the home for voltage control, speed control, frequency changing, and power conversion, generally at a lower cost, with increased efficiency and reduced maintenance than the devices they replace. The use of shunt power capacitors to improve system operating efficiencies also has a significant influence on harmonic levels. Capacitors do not generate harmonics, but provide network loops for possible local or general resonance conditions. Even though capacitors do not generate harmonics, they can influence the magnitudes of harmonic voltages and currents that occur on the utility system as well as the customer loads [B1].

The proper application of capacitors in a harmonic environment is determined by the following factors:

- a) Capacitor unit limitations as defined in IEEE Std 18-1992.
- b) System distortion limits as recommended in IEEE Std 519-1992.
- c) Other operating and application considerations of the shunt power capacitor bank.

5.5.1 Capacitor limitations

The effect of the harmonic components on the capacitor bank is to cause additional heating and higher dielectric stress. IEEE Std 18-1992 gives limitations on voltage, current, and reactive power for capacitor banks, which can be used to determine the maximum allowable harmonic levels. IEEE Std 18-1992 indicates that the capacitor can be applied continuously within the following limitations, including harmonic components:

- a) 110% of rated rms voltage
- b) 120% of rated peak voltage
- c) 180% of rated rms current
- d) 135% of rated reactive power

Despite this attempt to overrate the capacitors for unusual conditions, such as harmonics, many harmonic problems show up first at shunt power capacitor banks, either in the form of blown fuses or capacitor unit failures. The reason for this is that capacitor banks are in many cases part of a resonant loop, resulting in

magnification of specific harmonic components. The resulting harmonic voltages and currents are highest at the capacitor bank.

5.5.2 Distortion limits

The recommended voltage distortion limits from IEEE Std 519-1992 are summarized in table 8. In general, waveform distortion is usually described by its total harmonic distortion (THD). Voltage THD is defined as follows:

$$THD = \frac{\sqrt{\sum_{n=2}^{\infty} V_H^2}}{V_1} \cdot 100\%$$

where

THD is the total harmonic distortion

V_H is the magnitude of the voltage at harmonic H

V_1 is the magnitude of the voltage at the fundamental frequency

Table 8—Voltage distortion limits for medium- and high-voltage power systems

Power system voltage level (kV)	Total voltage THD (%)
69 and below	5.0
greater than 69 through 161	2.5
greater than 161	1.5

5.5.3 Operating and application considerations

Other operating and application conditions that should be included in evaluating the harmonic condition are given as follows:

- The system operating voltage at a capacitor location may exceed the nominal rating, often approaching 105%.
- Unbalances within a capacitor bank, especially due to individual fuses operating, typically are allowed to reach 10% before unbalance detection schemes take the bank out of service.
- If a system has been analyzed to ensure that the THD is less than the levels defined by IEEE Std 519-1992 under normal conditions, it is possible that the distortion will increase significantly during capacitor bank unbalance conditions.
- Although IEEE Std 18-1992 indicates a current limitation of 180%, the fusing is seldom, if ever, based on this number. Fuse ratings are typically chosen based on currents anywhere in the range of 125% to 165% of capacitor rating. Based on other selection criteria and discrete fuse sizes, even fuse current ratings in excess of 180%, which is the capacitor limitation, are possible. Thus, it becomes evident why in some severe harmonic cases fuses blow, while in others, capacitors fail during excessive harmonic conditions.
- Capacitors are allowed a tolerance of 0 to +15% on their kilovar rating by standards.

5.6 Protection

The following discussion is intended to complement IEEE Std C37.99-1990, in which the protection of shunt power capacitor banks is evaluated in detail.

The protection of substation capacitor banks includes the following components:

- a) Individual capacitor unit fusing
- b) Unbalance relaying
- c) Overcurrent relaying
- d) Surge arresters
- e) Phase voltage relays
- f) Periodic visual inspections

5.6.1 Individual capacitor unit fusing

The function of the capacitor fuse is to sense and indicate the failure of a single capacitor unit and remove the unit from service fast enough to prevent case rupture and damage to other units. At the same time, it is desirable that the fuse withstand the normal capacitor bank conditions without spurious operations.

To withstand normal conditions, it is desirable that the fuse be sized to withstand the following conditions:

- a) *Maximum continuous current.* This includes allowances for harmonics, capacitor unit tolerance, and overvoltage.
- b) *Switching inrush current.* This is a concern for back-to-back capacitor switching. Current-limiting reactors may be used to change the magnitude and frequency of the inrush current to an acceptable level, while switch closing resistors may be used to damp the current to acceptable levels. Significant fuse I^2t duty may be produced by restriking of the switching device during opening.
- c) *Lightning surge currents.* This is more of a concern for pole-mounted racks and is seldom a problem for substation banks.
- d) *Discharge current into a failing unit.* When a capacitor unit fails, i.e. shorts, the adjacent capacitors discharge into it. The fuses on the good capacitors should withstand this high-frequency outrush current into the failed units.

To ensure that the fuse will clear properly and prevent case rupture of the failed unit and damage to other units, the fuse should be sized to

- a) Withstand the maximum 60 Hz current expected
- b) Remove the failed unit without resulting in excessive overvoltages on good units
- c) Coordinate with the capacitor case rupture curve for the failed unit
- d) Withstand the energy discharge from parallel good units to the failed unit

In some applications, it may be difficult to meet all of these objectives. In such cases, trade-offs among the criteria are necessary.

5.6.2 Overcurrent relaying

In setting relays for fault current protection, the magnitude and time duration of inrush and outrush currents are considered so that false trips do not occur.

5.6.3 Unbalance relaying

When a fuse blows in a capacitor bank, an increase in the fundamental frequency voltage occurs on the remaining units in that series group. An unbalance detection scheme is employed to monitor such conditions

and to take action as required. This scheme usually includes three levels of action (see IEEE Std C37.99-1990):

- a) *Alarm for low level of unbalance.* Overvoltage on good units is less than 110%. The delay is usually 4 s or greater.
- b) *Trip capacitor bank switching device for higher level of unbalance.* Overvoltage on good units is greater than 110%. The delay is usually 4 s or greater.
- c) *Trip for severe bank unbalance.* This setting should be as fast as possible and coordinated with the maximum fuse clearing time. The delay is often 0.3 to 0.5 s.

5.6.4 Surge arresters

Surge arresters may be applied at the capacitor bank to limit transient overvoltages on the capacitor as well as on other system equipment. Applying surge arresters on the capacitor side of the switch can help to reduce switch recovery voltages for an ungrounded-wye capacitor bank. See [B13] for a detailed discussion.

5.6.5 Phase voltage relays

The application of capacitors inherently results in a voltage rise at that point in the system. To protect the capacitors and other station equipment against long-term overvoltage conditions, phase voltage relays are sometimes applied at the bus.

6. Special capacitor applications

This clause describes the considerations for applying shunt power capacitors in the following special applications:

- a) Harmonic filters
- b) Motors
- c) Surge protection

These special capacitor applications also require consideration of the previous clauses of this guide relating to purpose and ratings of capacitors, limitations, bank size, etc.

6.1 Harmonic filters

The levels of harmonic voltages and currents on power systems has generally increased as more nonlinear devices, such as solid-state power conversion equipment, are applied. Adding capacitors and/or filters to improve system-operating efficiencies can introduce harmful parallel resonances that are excited by harmonic-producing loads and equipment on electrical systems.

Utilizing the capacitors to form harmonic filters permits control of the harmonic current path in the local power system and reduction of voltage distortion. Harmonic filter applications include the following:

- a) General voltage distortion control
- b) Filtering for large rectifier loads and arc furnace systems
- c) Control of harmonic currents at dc transmission converter terminals and static var systems

Many good sources exist that discuss these types of applications; see [B2], [B4], [B10], [B11], [B14], and [B15].

The most common shunt filters are single-tuned filters, double-tuned filters, and high-pass filters. The filter type implemented depends on the nature of the harmonic problem being solved. The general layout of shunt filters is shown in figure 20.

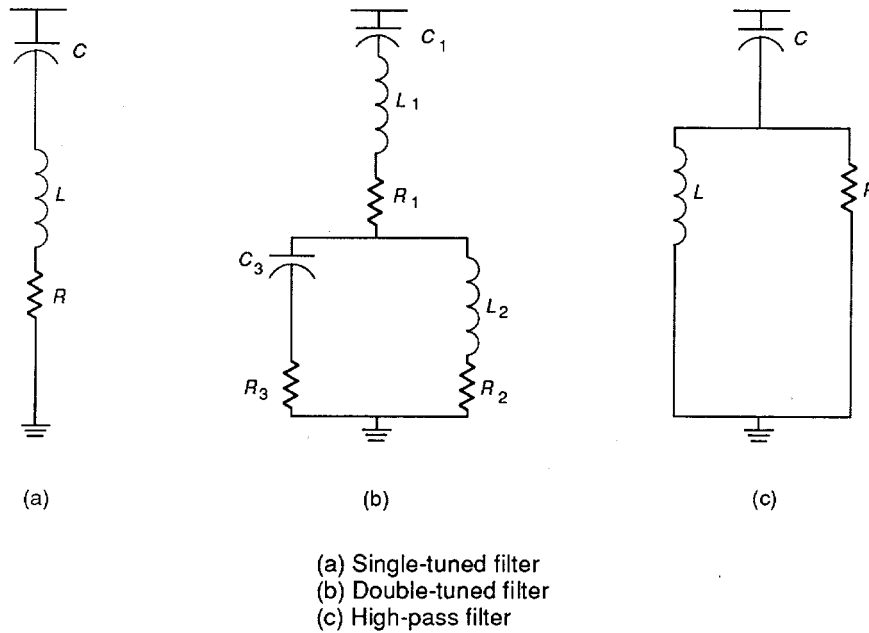

Figure 20—Shunt filters

The allowable overload limits of capacitors based on IEEE Std 18-1992 are as follows:

- a) Kilo-var—135%
- b) RMS voltage—110%
- c) Sum of peak voltages—120%
- d) RMS current—180%

These overload capabilities are to be used for contingency conditions while normal duty is to be within the capacitor rating. All of these parameters should be checked when applying capacitors in a harmonic environment, especially if the capacitors are part of a filter.

The use of an inductor in series with a capacitor results in a voltage rise at the capacitor terminals given by the following formula:

$$V_{\text{cap}} = \left(\frac{n^2}{n^2 - 1} \right) \cdot V_{\text{sys}}$$

where

- n is the tuned harmonic of the filter
- V_{sys} is the system line-to-line voltage, in volts
- V_{cap} is the capacitor line-to-line voltage, in volts

When verifying the maximum voltage rise, the worst conditions should be taken into account. Maximum system voltage together with maximum capacitance tolerance (typically 10%) and maximum inductor tolerance (typically 5%) should be used. Taking into account these tolerances, will yield the maximum voltage rise across the reactor.

When using a capacitor bank in a system with a voltage lower than the capacitor rating, the following formula can be used to determine the effective kilovar:

$$kvar_{\text{cap}} = \frac{(V_{\text{sys}})^2}{X_C \cdot 1000}$$

where

- V_{sys} is the system line-to-line voltage, in volts
- X_C is the capacitive reactance at the fundamental frequency

The presence of the filter reactor changes the effective kilovar output of the bank. The new output is calculated by the following formula:

$$kvar_{\text{filt}} = \frac{(V_{\text{sys}})^2}{(X_C - X_L) \cdot 1000}$$

where

- V_{sys} is the system line-to-line voltage, volts
- X_C is the capacitive reactance at the fundamental frequency
- X_L is the inductive reactance at the fundamental frequency

Therefore, the designer may have to do several iterations before finally deciding on the capacitor bank ratings if reactive compensation is also required from the filter.

The current limit, although 180% by standards, may be lower because individual capacitor units are usually fused at 125% to 165% of their current rating.

When designing a filter, the rms voltage, rms current, and the peak voltage on the capacitor bank are to be limited to the rated values for normal conditions. This is done so that the overrating capabilities are available to cover system overvoltages and bank unbalance conditions. The harmonic components may increase significantly for bank unbalance conditions. In specifying capacitor equipment for these applications, the following information should be included:

- a) The system line-to-line voltage
- b) The bank capacitance (microfarads)
- c) The values of other relevant circuit components (R in ohms, L in microhenries or millihenries, etc.)
- d) The harmonic voltage or current profile across the filter or preferably across the capacitor bank for the range of required frequencies
- e) The expected duty cycle or repetition rate of the above currents and voltages

Capacitor fuses are not intended to protect the unit from overload currents. When a unit shorts, the fuse is expected to clear and isolate the faulted unit, thus minimizing the probability of case rupture and reducing

the effect of the unit failure on bank operation and the system. In recent years the trend has been to fuse closer and closer to the current rating of the capacitor, attempting to have more rapid fuse operation when a unit fails. Excessive harmonic currents may cause unwanted fuse operations. These misoperations then cause voltage unbalances within the bank, which can result in capacitor unit failures that otherwise would not have occurred. For this reason filter design and fuse selection should be carefully considered. The criteria are described in detail in clauses 4 and 5.

6.2 Motor applications

6.2.1 Capacitors and motors

Shunt power capacitors are frequently used to improve the power factor of circuits or industrial power systems with a large induction motor load. Several safeguards should be considered when applying capacitors in conjunction with motors [B9], [B20].

Capacitors permanently connected in parallel with medium voltage motors should be limited in size to the electrical no-load reactive component of the motors. This limitation is to prevent overvoltage due to self-excitation when the motor and capacitor combination is disconnected from the electrical supply and the rotor continues to rotate due to mechanical inertia. IEEE Std 141-1986 contains a table of maximum recommended capacitor ratings to be applied with induction motors when the capacitors are switched with motors. When special application motors are involved or questions arise, the recommendation should be checked with the motor manufacturer.

When capacitors larger than the rating permitted above are used, they should either be connected ahead of the motor switch or have a separate switch that automatically disconnects the capacitor when the motor is disconnected.

Capacitors switched with motors prolong the duration of residual voltage in the motor as it slows down after de-energization. High transient torques that can damage motor and equipment are possible if open transition transfer is used or the motor is re-energized before the residual voltage has decayed to a safe level (20–25%).

6.2.2 Motor starting

An undesired characteristic of large squirrel-cage motors and industrial synchronous motors is that they draw several times their full-load current from their supply when starting. The power factor during starting is usually in the range of 0.15 to 0.30 lagging. A typical starting curve is illustrated in figure 21. The actual shape and magnitude of the starting current curve depends on the motor design, the voltage at the motor terminals during starting, and the speed-torque characteristic of the mechanical load connected to the motor. After starting, the typical reactive current requirement of a running motor is 30% of its full-load current.

The starting current flowing through the system impedances can result in an unacceptable voltage drop that may be large enough to cause contactors to drop out and influence the ability of the motor to start.

Shunt power capacitors are sometimes used to reduce the voltage dip when starting a large motor. Their effect is to reduce the reactive component of the input kilovoltamperes. With this method, the high inductive component of the normal starting current is offset, at least partially, by the addition of capacitors to the motor bus during the starting period.

The capacitor size needed for this purpose is usually 2–3 times the motor full-load kilovoltampere rating. In order to control the voltage properly, the capacitor is usually switched out in steps as the motor accelerates. (See figure 22.) Due to the large kilovar size of these capacitors, they are usually in the circuit for only a few seconds during motor starting.

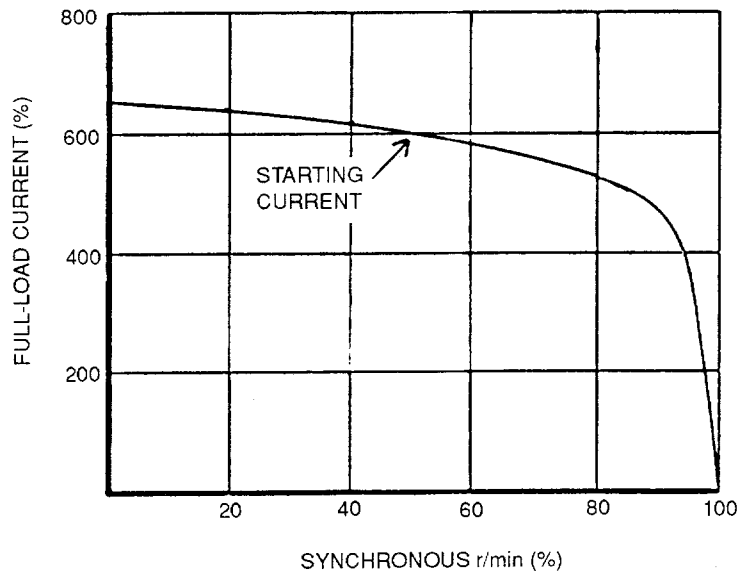

Figure 21—Typical motor starting curve

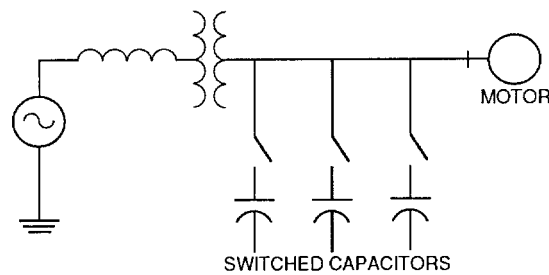

Figure 22—Motor starting capacitor application

In determining the voltage rating of the capacitors, they should be within the overvoltage capability defined in table 6.

6.3 Surge capacitors

Certain types of capacitors, when properly applied, will limit the insulation damaging effects of voltage surges. These are referred to as surge capacitors. They have been used as part of the overvoltage protection schemes, most often for rotating machinery and arc furnace transformers. (See figure 23.)

The stress on the major insulation of a rotating machine—the insulation between winding and frame—is determined mainly by the magnitude of the surge voltage to ground. However, the stress on the insulation between the turns of the winding is more a function of the rate-of-rise of the surge voltage as it penetrates the winding. Proper protection of rotating machines requires not only limiting the surge voltage magnitude at the machine terminals, but also reducing the slope of the wavefront of the incoming surge. The function of the surge capacitor is to reduce the slope of the wavefront of an incoming surge [B9].

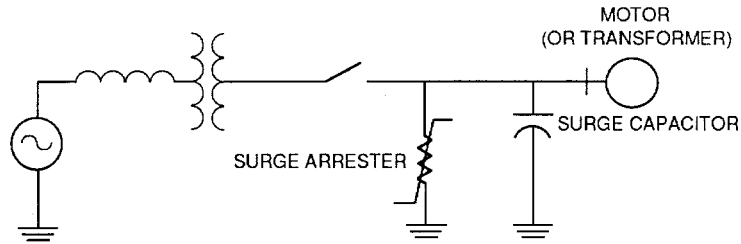

Figure 23—Surge capacitor application

Surge capacitors are also used to protect equipment, especially transformers, from transient overvoltages due to current chopping. Current chopping is the action of interrupting low levels of currents prior to a natural current zero. When this happens, energy is trapped in the transformer inductance, which is subsequently interchanged with circuit capacitance producing a voltage surge. The magnitude of the voltage surge is conservatively calculated by the following formula:

$$V = I_c \sqrt{\frac{L_m}{C}}$$

where

- I_c is the chopped current level
- L_m is the transformer magnetizing inductance
- C is the capacitance on the transformer side of the switch

As can be seen in the above formula, the voltage surge produced is independent of the system voltage level; therefore, this phenomenon is most troublesome on low-voltage, low-BIL systems. The addition of a surge capacitor will act to reduce this transient.

Surge capacitors may see transient voltage duties in excess of those defined in IEEE Std 18-1992. Consequently, these capacitors are specially designed for the duties required in these applications. Typical values of surge capacitors are given in table 9.

Table 9—Typical capacitance values for line-to-ground surge capacitors

Rated system voltage (kV)	Capacitance (μf)
2.4–6.9	0.5
13.8	0.25
24.0	0.125
34.5	0.0833*

*One 0.25 μf, 13.8 kV in series with one 0.125 μf, 24 kV (one capacitor unit must be insulated from ground).

7. Inspection and maintenance

7.1 General

This clause describes the general considerations for maintenance and inspection of shunt power capacitor banks for substation and distribution (pad-mounted and pole-mounted) applications.

All capacitor banks should be inspected and electrical characteristics measured upon initial installation and periodically, or as required, throughout their service life. Since capacitors are “closed systems,” a visual inspection alone cannot determine the condition of all individual capacitors.

7.2 Safety and personnel protection

Normal good safety practices should be followed during installation, inspection, and maintenance of capacitors. In addition, there are procedures that are unique to capacitors that should be followed for the protection of personnel and equipment as given in the National Electrical Safety Code (NESC) (ANSI C2-1990). Listed below are several precautions that should be observed.

7.2.1 Clearance and grounding

After a capacitor bank has been de-energized, wait at least 5 min before approaching it. This is to allow enough time for the internal discharge resistors in each capacitor unit to dissipate the stored energy. These resistors are designed to reduce the voltage across the individual capacitor units to less than 50 V within 5 min; however, one should always apply grounding leads to all three phases to short out and ground the bank. On larger substation banks, permanent grounding switches may be installed to accomplish this.

Even after the bank has been grounded, it is recommended that individual capacitor units be shorted and grounded before personnel contact them to assure that no stored energy is present. (In some circumstances, failure of the internal resistor could leave a stored charge on an individual capacitor unit.)

7.2.2 Bulged capacitor units

Excessively bulged units indicate excessive internal pressure caused by overheating and/or creation of gasses during a probable arcing condition. These units should be handled carefully. The manufacturer should be consulted if there are questions regarding special handling of these units.

7.2.3 Leaking capacitor units

When handling capacitors with leaking fluid, avoid contact with skin and prevent entry into sensitive areas, such as eyes. Handling and disposal of capacitor insulating fluid should follow the methods required by federal, state, and local regulations.

7.2.4 Combustible fluid

Some units contain combustible liquid and their location should be chosen with consideration given to the possibility of fire and its containment in the event of capacitor failure. See the National Electrical Code (NEC) (ANSI/NFPA 70-1993) for location limitations.

7.2.5 Re-energizing

When returning a capacitor to service, verify that all shorts and grounds that were installed for maintenance have been removed. Allow a minimum of 5 min between de-energization of a capacitor bank and re-energization of the bank to allow enough time for the stored energy to dissipate.

7.3 Initial inspection, measurements, and energization

The initial inspection should include the following items:

- a) Verify mechanical assembly of the capacitor equipment for proper electrical clearances and structural soundness.
- b) Some utilities have found it useful to measure the capacitance of new capacitor units to verify proper markings and establish a benchmark for future comparison.
- c) Ensure flipper devices on fuses are properly installed for successful operation of the fuse.
- d) Check electrical connections for proper installation and good electrical contact. Verify that unit terminal nuts are torqued properly. Check individual fuse connections to ensure that they are tight and make good contact, as listed:
 - 1) The fuse tube cap-to-bus connection for proper torque.
 - 2) The fuse tube-to-cap connection for proper torque.
 - 3) On expulsion fuses, ensure that the “button heads” make good contact with the tube cap; on those fuse links with removable “button heads,” ensure that the button heads are properly assembled on the fuse link.
- e) Clean all insulators, fuses, and bushings to prevent the possibility of dirty porcelain creating a flash-over danger.
- f) Inspect insulators and bushings for cracks or breaks.
- g) Inspect for damaged bushings and cases to identify any source of leaks.
- h) Test the operation of all controls and load break, disconnect, and grounding switches prior to energizing the capacitor.
- i) Prior to energization, verify that the capacitance values of each of the phases are sufficiently close to allow coordination with any relaying scheme utilized. At a minimum, this capacitance unbalance should not result in a voltage of more than 110% of rated voltage on any one unit.
- j) On those units with capacitance unbalance protection equipment, verify that such equipment operates properly. (See IEEE Std C37.99-1990.)
- k) Immediately after energization, verify that the voltage boost obtained is sufficiently close to the expected value. Verify that impressed voltage, capacitor current, and kilovar are within the limits of capacitor ratings.
- l) Within 8 to 24 h after the capacitor is put in service, it is highly desirable to recheck the bank for any blown fuses, bulged units, and proper phase current balance.

7.4 Periodic inspection, measurements, and maintenance

Substation and distribution banks should be inspected and electrical measurements made periodically, or as required, throughout their service life. The frequency of inspections should be determined by local conditions and requirements (i.e., environmental conditions, percent of time the capacitor bank is switched “on,” and number of “on” and “off” switching operations).

7.4.1 Visual inspections

Visual inspections should include the following items:

- a) Check for blown capacitor fuses, capacitor case leaks, bulged cases, discolored cases, and ruptured cases.
- b) Check the ground for spilled dielectric fluid.
- c) Check for dirty insulating surfaces and cracked bushings.
- d) Check for signs of overheated electrical joints.
- e) Check for open switches and “tripped” protective devices.
- f) Check for vandalism and damage due to gunfire.

- g) On housed and pad-mounted banks, verify that any required locking device is in place, and inspect the exterior for corrosion, oil leaks, (around structure) and ensure that any required warning sign (e.g., “High Voltage”) is properly installed and legible.

7.4.2 Physical inspection and measurements

Physical inspections and measurements should include the following items:

- a) Check for loose connections, frayed leads, faulty fuse tubes, and faulty ejector spring assemblies.
- b) Fuses should be inspected for evidence of overheating or other damage.
- c) Verify proper settings and operation of protective and/or control devices, switches, and potential and/or current transformers.
- d) Equipment exposed to weathering should be repainted, if necessary, to prevent corrosion.
- e) The capacitance of the individual units should be measured and compared with their previous reading (see 7.5).
- f) Any other maintenance operations suggested in the manufacturer’s instructions.

7.4.3 Banks with excessive failures

Banks with excessive unit failures and/or blown fuses should be inspected on a more frequent basis. In addition to the items in 7.4.1 and 7.4.2, the inspections may also include measurements of transient and/or harmonic voltages and currents impressed upon the bank to ensure that they are within the limits of the capacitor ratings. The manufacturer should be consulted for assistance.

7.5 Field testing

Several electrical devices are available in the market to measure capacitance, power factor, impedance, resistance, and voltage withstand. While all of these instruments can detect an open or shorted capacitor, some can detect a partially shorted capacitor as well.

One of the most popular of these devices for field use is a digital capacitance meter. This is a small, battery-operated, low-voltage device that generally gives very accurate readings. However, it may fail to detect some internal failures that require high breakdown voltage.

Another test used by some utilities that is very useful is an ac test to detect a shorted or open capacitor element. The applied current and voltage should be proportional to the rating of the capacitor and be within IEEE Std 18-1992 tolerances [B17].

Since capacitors are usually made up of series groups of parallel capacitor elements, the measurement of the capacitance of a unit can be a direct indication of the internal condition of the unit. Capacitor standards specify that capacitors shall give not less than the rated reactive power at rated sinusoidal voltage and frequency, and not more than 115% of this value, measured at 25 °C uniform case and internal temperature. Based on this tolerance, capacitor units with capacitance readings outside the tolerance, of –0% to +15% should be replaced. However, when capacitance readings are made at temperatures much colder than 25 °C, the capacitance could read slightly above the +15% value and readings at temperatures much warmer than 25 °C could read slightly below the –0% value. Since design and manufacturing tolerances vary, the manufacturer should be consulted concerning the capacitance value for partially failed capacitors.

Some utilities have found it very useful to record capacitance readings of each unit in the bank. Significant changes in capacitance readings from one inspection to the next may indicate capacitor element failures and may require replacement of the unit.

8. Bibliography

[B1] Arrillaga, J., Bradley, D. A., and Bodger, P. S., *Power System Harmonics*. New York: John Wiley & Sons, 1985.

[B2] Bahrman, M., Crane, L., Cooper, R., and Lordeon, W., "Operating Experience with a Static VAR Generator on the MP&L System," *Proceedings of the International Symposium on Controlled Reactive Compensation*, Varennes, Quebec, Sept. 1979, pp. 18–36.

[B3] Bayless, R. S., Selman, J. D., Truax, D. E., and Reid, W. E., "Capacitor Switching and Transformer Transients," *IEEE Transactions on Power Delivery*, vol. 3, no. 1, Jan. 1988, pp. 349–57.

[B4] Byerly, R. T., Pozhaniak, D. T., and Taylor, Jr., E. R., "Static Reactive Compensation for Power Transmission Systems," *IEEE Transactions on Power Apparatus and Systems*, vol. PAS-101, Oct. 1982, pp. 3997–4005.

[B5] CFR (Code of Federal Regulations), Title 40, Part 761: Polychlorinated Biphenyls (PCBs) Manufacturing, Processing, Distribution in Commerce and Use Prohibitions Use in Electrical Equipment, USEPA.

[B6] Clinard, Kay N., "Distribution Automation: Research and the Emergence of Reality," *IEEE Transactions on Power Apparatus and Systems*, vol. PAS-103, no. 8, Aug. 1984, pp. 2071–75.

[B7] Greenwood, Alan. *Electrical Transients in Power Systems*. New York: John Wiley & Sons, 1971.

[B8] IEEE Std 262B-1977, IEEE Trial-Use Standard Dielectric Test Requirements for Power Transformers for Operation on Effectively Grounded Systems 345 kV and Above (Trial-Use Supplement to IEEE Std 262-1973, ANSI C57.12.90-1973).

[B9] IEEE 79 EHO 144-6 PWR, Chapter 8: D.W. Jackson, "Surge Protection of Rotating Machines," *Surge Protection in Power Systems*, Power Engineering Society, 1979.

[B10] IEEE 84 EHO 221-2 PWR, "Tutorial on Power System Harmonics," *Power Systems Harmonic Tutorial*, Power Engineering Society, 1984.

[B11] Keane, J., Chu, D., Gutman, R., Rahman, M., and Veraas, O., "Application of Static VAR Compensators for Steady State and Dynamic Voltage Control," *Proceedings of the International Symposium on Controlled Reactive Compensation*, Varennes, Quebec, Sept. 1979, pp. 228–51.

[B12] McCauley, T. M., Pelfrey, D. C., Roettger, W. C., and Wood, C. E., "The Impact of Shunt Capacitor Installations on Power Circuit Breaker Applications," *IEEE Transactions on Power Apparatus and Systems*, vol. 99, no. 6, Nov./Dec. 1980, pp. 2210–22.

[B13] McGranaghan, M. F., Reid, W. E., Law, S. W., and Graham, D. W., "Overvoltage Protection of Shunt Capacitor Banks Using MOV Arresters," *IEEE Transactions on Power Apparatus and Systems*, vol. 104, no. 8, Aug. 1984, pp. 2326–36.

[B14] Miller, T. J. E., *Reactive Power Control in Electric Systems*. New York: John Wiley & Sons, 1982.

[B15] Moore, A. H., "Application of Power Capacitors to Electro-chemical Rectifier Systems," *IEEE IAS Petroleum and Chemical Conference Proceedings*, no. 76 CH 1109-8-1A, August 1976.

[B16] NEMA CP 1-1988, Shunt Capacitors.

[B17] O'Regan, T. M. and Burkum, M. E., "Development of a System for Field Testing of High Voltage Capacitors on Electrical Utility Systems with In-Circuit Measurement," *IEEE Transactions on Power Apparatus and Systems*, Vol. PAS-103, no. 10, Oct. 1984, pp. 3069–73.

[B18] Pflanz, H. M. and Lester, G. N., "Control of Overvoltages on Energizing Capacitor Banks," *IEEE Transactions on Power Apparatus and Systems*, vol. PAS-92, no. 3, May/June 1973, pp. 907–15.

[B19] Schultz, A. J., Johnson, J. B., and Schultz, N. R., "Magnification of Switching Surges," *AIEE Transactions on Power Apparatus and Systems*, Feb. 1959, pp. 1418–26.

[B20] Shula, W. E., "Capacitors Help Start Large Motors," *Electrical World*, Nov. 1, 1974.